

A Division of Systems, LLC

**DLM**  
**DOCK LEVELER**  
**MANUFACTURING**

# DA Series

## Dock Leveler

### Owner's/User's Manual



**DLM** • Division of Systems, LLC • W194 N11481 McCormick Drive • Germantown, WI 53022

800.643.5424 • fax: 262.255.5917 • [www.dlmdocks.com](http://www.dlmdocks.com) • [techservices@loadingdocksystems.com](mailto:techservices@loadingdocksystems.com)

Printed in U.S.A.

© 2019 Systems, LLC - All Rights Reserved

Manual No. 4111-0011

Nov. 2019

# Table Of Contents

	Page		Page
<b>Precautions</b>		<b>Maintenance</b>	
Recognize Precautionary Information.....	1	Maintenance Precautions .....	28
General Operational Precautions .....	1	Periodic Maintenance .....	30
Operational Precautions.....	2		
Safety Decals .....	4	<b>Adjustments</b>	
Placard.....	4	Adjust Lip Latch & Lip Actuator Spring	
Owner's/User's Responsibilities.....	6	Tension.....	32
		Adjust Lip Stop Bolt.....	34
<b>Introduction</b>		Adjust Lip Assist Chain and Shackle.....	35
General Information .....	8		
Component Identification .....	9	<b>Troubleshooting</b>	
		Troubleshooting .....	36
<b>Installation</b>			
Installation Precautions.....	10	<b>Parts</b>	
Prepare Pit .....	12	Standard Control Box .....	38
Prepare Dock Leveler.....	13	Optional Electrical Parts (Control Box).....	39
Install Dock Leveler.....	14	Lip Activation (pre-2012) .....	40
Install Control Panel and Wiring.....	20	Lip Activation (2012-present) .....	42
Placard Installation Instructions.....	22	Airbag and Support Pallet.....	44
Put New Dock Leveler Into Service .....	23	Blower Motor Assembly .....	46
		Frame and Platform.....	48
<b>Operation</b>		Below Dock Control (pre-8/2019).....	50
Operational Precautions.....	24	Below Dock Control (8/2019-present) .....	51
Ramp Loading/Unloading Instructions .....	26	Weather Seals .....	52
End Loading/Unloading Instructions .....	27		
		<b>Miscellaneous</b>	
		Customer Information.....	53
		Warranty .....	Back Cover

## Recognize Precautionary Information

### Safety-Alert Symbol



The Safety-Alert Symbol is a graphic representation intended to convey a safety message without the use of words. When you see this symbol, be alert to the possibility of death or serious injury. Follow the instructions in the safety message panel.

### **DANGER**

The use of the word DANGER signifies the presence of an extreme hazard or unsafe practice which will most likely result in death or severe injury.

### **WARNING**

The use of the word WARNING signifies the presence of a serious hazard or unsafe practice which could result in death or serious injury.

### **CAUTION**

The use of the word CAUTION signifies possible hazard or unsafe practice which could result in minor or moderate injury.

### **NOTICE**

The use of the word NOTICE indicates information considered important, but not hazard-related, to prevent machine or property damage.

## SAFETY INSTRUCTIONS

Indicates a type of safety sign, or separate panel on a safety sign, where safety-related instructions or procedures are described.

## General Operational Precautions



Read and understand the Owner's/User's Manual and become thoroughly familiar with the equipment and its controls before operating the dock leveler.

Never operate a dock leveler while a safety device or guard is removed or disconnected.

Never remove DANGER, WARNING, or CAUTION signs, Placards or Decals on the equipment unless replacing them.

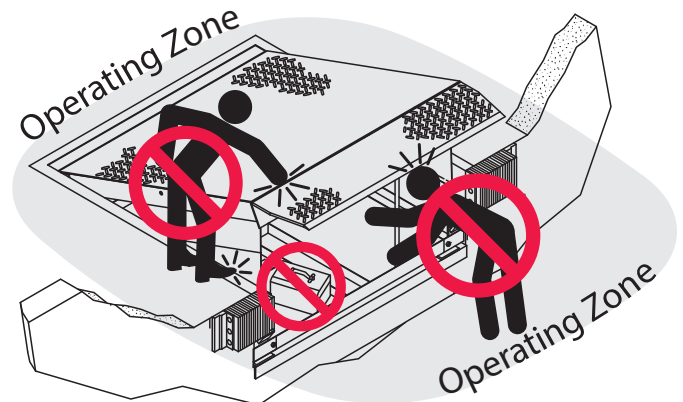

Figure 1

Do not start the equipment until all unauthorized personnel in the area have been warned and have moved outside the operating zone (see Figure 1).

Remove any tools or foreign objects from the operating zone before starting.

Keep the operating zone free of obstacles that could cause a person to trip or fall.



**WARNING:** This product can expose you to chemicals including lead, which are known to the State of California to cause cancer or birth defects or other reproductive harm. For more information go to [www.P65Warnings.ca.gov](http://www.P65Warnings.ca.gov)

# PRECAUTIONS

## Operational Precautions



Learn the safe way to operate this equipment. Read and understand the manufacturer's instructions. If you have any questions, ask your supervisor.

### **DANGER**



Stay clear of dock leveling device when transport vehicle is entering or leaving area.



Do not move or use the dock leveling device if anyone is under or in front of it.



Keep hands and feet clear of pinch points. Avoid putting any part of your body near moving parts.

### **WARNING**



Chock/restrain all transport vehicles. Never remove the wheel chocks or release the restraining device until loading or unloading is finished, and transport driver has been given permission to drive away.



Do not use a broken or damaged dock leveling device or restraining device. Make sure proper service and maintenance procedures have been performed before using.



Make sure lip overlaps onto transport vehicle bed at least 4 in. (102 mm).



Keep a safe distance from both side edges.

Operational Precautions

**! WARNING**



Do not use dock leveling device if transport vehicle is too high or too low.

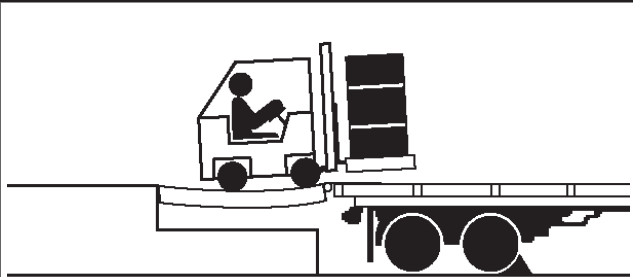

Do not overload the dock leveling device.



Do not operate any equipment while under the influence of alcohol or drugs.

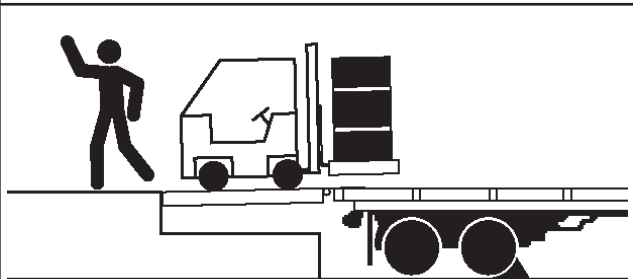

Do not leave equipment or material unattended on dock leveling device.

# PRECAUTIONS

## Safety Decals



1751-0329



1751-0330 Two positions one on top of each fork pocket.

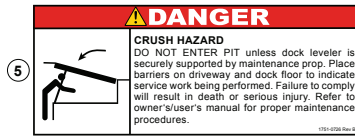

1751-0726

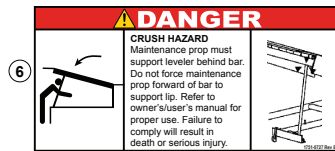

1751-0727



1751-0729

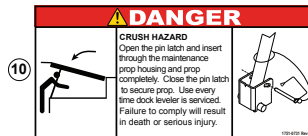

1751-0138

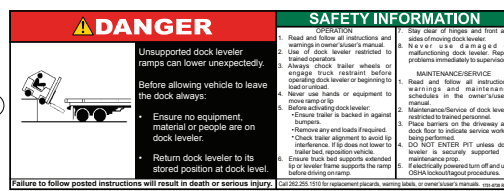
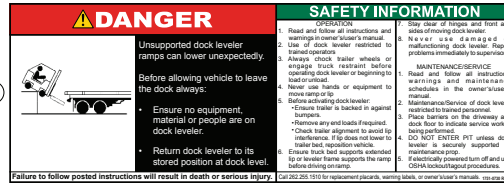

1751-0730

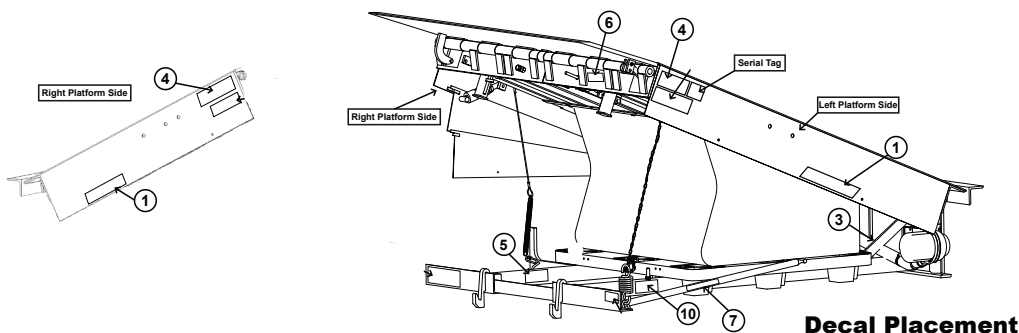



Figure 2

Decal Placement for DA Series

## Placard



# DANGER

## OPERATING INSTRUCTIONS

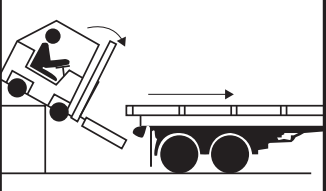

- Read and follow all instructions, warnings, and maintenance schedules in the manual and on placards.
- Operation and servicing of dock leveler is restricted to authorized personnel.

### POWERED DOCK LEVELERS

#### NORMAL OPERATION

1. Raise the platform by Pressing and holding the RAISE button.
2. Hold the RAISE button until the lip is fully extended, then release the RAISE button. The platform will lower until lip is resting on the transport vehicle.

#### STORING LEVELER

1. Press the RAISE button until the lip is completely folded. When the lip is folded, release the RAISE button. The platform will lower returning to the cross-traffic position.

#### BELOW DOCK ENDLOADING

- (AIR POWERED ONLY)** Press and hold the RAISE button until the leveler is 12" above dock level. Pull the below dock level chain until the leveler lowers the full below dock position.
- (HYDRAULIC ONLY)** Press and hold the RAISE button until the leveler is fully raised. As the lip starts to extend, release the RAISE button. The leveler will lower to the below dock position provided the lip extension allows the lip to clear the lip keepers.
- (HYDRAULIC WITH INFINITE LIP CONTROL)** If equipped, raise the platform by Pressing and holding the RAISE button. When the lip is just above the lip keepers, simultaneously Press and hold the RAISE button and the LIP OUT button until lip has extended beyond the lip keepers. Release both buttons.

**FAILURE TO FOLLOW THESE INSTRUCTIONS WILL RESULT IN DEATH OR OTHER SERIOUS INJURY.**



Scan to view our owner's/user's manuals online.  
[www.LoadingDockSystems.com](http://www.LoadingDockSystems.com)  
**1.800.643.5424**  
 Call for additional placards, or manuals, or with questions regarding proper use, maintenance, and repair of dock leveler.



WARNING: CANCER AND REPRODUCTIVE HARM  
[www.P65Warnings.ca.gov](http://www.P65Warnings.ca.gov)

1751-0874 Rev D

**NOTE: If equipped, Pressing E-STOP button will stop platform from lowering.**

1751-0874

# OWNER'S/USER'S RESPONSIBILITIES

---

- 1) The manufacturer shall provide to the initial purchaser and make the following information readily available to the owners/users and their agents, all necessary information regarding Safety Information, Operation, Installation and Safety Precautions, Recommended Initial and Periodic Inspections Procedures, Planned Maintenance Schedule, Product Specifications, Troubleshooting Guide, Parts Break Down, Warranty Information, and Manufacturers Contact Information, as well as tables to identify the grade(slope) for all variations of length or configuration of the dock leveling device and information identifying the maximum uncontrolled drop encountered when sudden removal of support while in the working range of the equipment.
- 2) When selecting loading dock safety equipment, it is important to consider not only present requirements but also future plans and any possible adverse conditions, environmental factors or usage. The owners/users shall provide application information to the manufacturer to receive recommendations on appropriate equipment specifications and capacity.
- 3) The owner/user must see all nameplates, placards, decals, instructions and posted warnings are in place and legible and shall not be obscured from the view of the operator or maintenance personnel for whom such warnings are intended for. Contact manufacturer for any replacements.
- 4) Dock leveling devices may become hazardous if the manufacturer's instructions regarding modifications or adjustments are not followed. Modifications or alterations of dock leveling devices shall only be made with prior written approval from the original manufacturer. These changes shall be in conformance with all applicable provisions of the MH30.1 standard and shall also satisfy all safety recommendations of the original equipment manufacturer of the particular application.
- 5) The owner/user should recognize the inherent dangers of the interface between the loading dock and the transport vehicle. The owner/ user should, therefore, train and instruct all operators in the safe operation and use of the loading dock equipment in accordance with manufacturer's recommendations and industry standards. Effective operator training should also focus on the owner's/user's company policies, operating conditions and the manufacturer's specific instructions provided with the dock leveling device. Maintaining, updating and retraining all operators on safe working habits and operation of the equipment, regardless of previous experience, should be done on a regular basis and should include an understanding and familiarity with all functions of the equipment. Owners/users shall actively maintain, update and retrain all operators on safe working habits and operations of the equipment.
- 6) An operator training program should consist of, but not necessarily be limited to, the following:
  - a) Select the operator carefully. Consider the physical qualifications, job attitude and aptitude.
  - b) Assure that the operator reads and fully understands the complete manufacturer's owners/users manual.
  - c) Emphasize the impact of proper operation upon the operator, other personnel, material being handled, and equipment. Cite all rules and why they are formulated.
  - d) Describe the basic fundamentals of the dock leveling device and components design as related to safety, e.g., mechanical limitation, stability, functionality, etc.
  - e) Introduce the equipment. Show the control locations and demonstrate its functions. Explain how they work when used properly and maintained as well as problems when they are used improperly.
  - f) Assure that the operator understands the capacity rating, nameplate data, placards and all precautionary information appearing on the dock leveling device.
  - g) Supervise operator practice of equipment.
  - h) Develop and administer written and practical performance tests. Evaluate progress during and at completion of the course.
  - i) Administer periodic refresher courses. These may be condensed versions of the primary course and include on-the-job operator evaluation.



# OWNER'S/USER'S RESPONSIBILITIES

---

- 7) Loading dock safety equipment should never be used outside of its vertical working range, or outside the manufacturer's rated capacity. It shall also be compatible with the loading equipment and other conditions related to dock activity. Please consult the manufacturer if you have any questions as to the use, vertical working range or capacity of the equipment. Only properly trained and authorized personnel should operate the equipment.
- 8) It is recommended that the transport vehicle is positioned as close as practical to the dock leveling device and in contact with both bumpers. When an industrial vehicle is driven on or off a transport vehicle during loading and unloading operations, the transport vehicle parking brakes shall be applied and wheel chocks or a restraining device that provides equal or better protection of wheel chocks shall be engaged. Also, whenever possible, air-ride suspension systems should have the air exhausted prior to performing said loading and unloading operations.
- 9) When goods are transferred between the loading dock and a trailer resting on its support legs/ landing gear instead of a tractor fifth wheel or converter dolly, it is recommended that an adequate stabilizing device or devices shall be utilized at the front of the trailer.
- 10) In order to be entitled to the benefits of the standard product warranty, the dock safety equipment must have been properly installed, maintained and operated in accordance with all manufacturer's recommendations and/ or specified design parameters and not otherwise have been subject to abuse, misuse, misapplication, acts of nature, overloading, unauthorized repair or modification, application in a corrosive environment or lack of maintenance. Periodic lubrication, adjustment and inspection in accordance with all manufacturers' recommendations are the sole responsibility of the owner/user.
- 11) Manufacturer's recommended maintenance and inspection of all dock leveling devices shall be performed in conformance with the following practices: A planned maintenance schedule program must be followed, only trained and authorized personnel shall be permitted to maintain, repair, adjust and inspect dock leveling devices, and only the use of original equipment manufacturer parts, manuals, maintenance instructions, labels, decals and placards or their equivalent. Written documentation of maintenance, replacement parts or damage should be kept. In the event of damage, notification to the manufacturer is required.
- 12) Loading dock devices that are structurally damaged or have experienced a sudden loss of support while under load, such as might occur when a transport vehicle is pulled out from under the dock leveling device, shall be removed from service, inspected by a manufacturer's authorized representative, and repaired or replaced as needed or recommended by the manufacturer before being placed back in service.

# INTRODUCTION

---

## General Information



Figure 3

This manual provides current information on the DA-series dock leveler. Due to ongoing product improvement, some parts may have changed, along with operation and troubleshooting methods. This manual describes these changes where applicable.

The DA-series is an air powered dock leveler that provides dependability and superior structure at a price which rivals most mechanical dock levelers. This leveler is available in a wide range of sizes and capacities and can be modified for special applications.

The DA-series dock leveler comes equipped with an electrical control panel, which allows push button operation of the dock leveler.

Each DA-series dock leveler unit has been factory tested to ensure satisfactory operation.

DA dock levelers are available in the following sizes, weight capacities, and options:

### Width

6 ft (1829 mm)  
6-1/2 ft (1981 mm)  
7 ft (2134 mm)

### Length

6 ft (1829 mm)  
8 ft (2438 mm)  
10 ft (3048 mm)

### Capacity (CIR\*)

25,000 lb (11,340 kg)  
30,000 lb (13,608 kg)  
35,000 lb (15,876 kg)  
40,000 lb (18,144 kg)  
45,000 lb (20,412 kg)  
50,000 lb (22,680 kg)

\* CIR (Comparative Industry Rating)

Call DLM to discuss available options to meet your specific needs.

Technical Service at 800-643-5424 or [techservices@loadingdocksystems.com](mailto:techservices@loadingdocksystems.com)

## Component Identification

Inspect package and all components. Report any missing or damaged items immediately and note on the shipping Bill Of Lading (BOL).

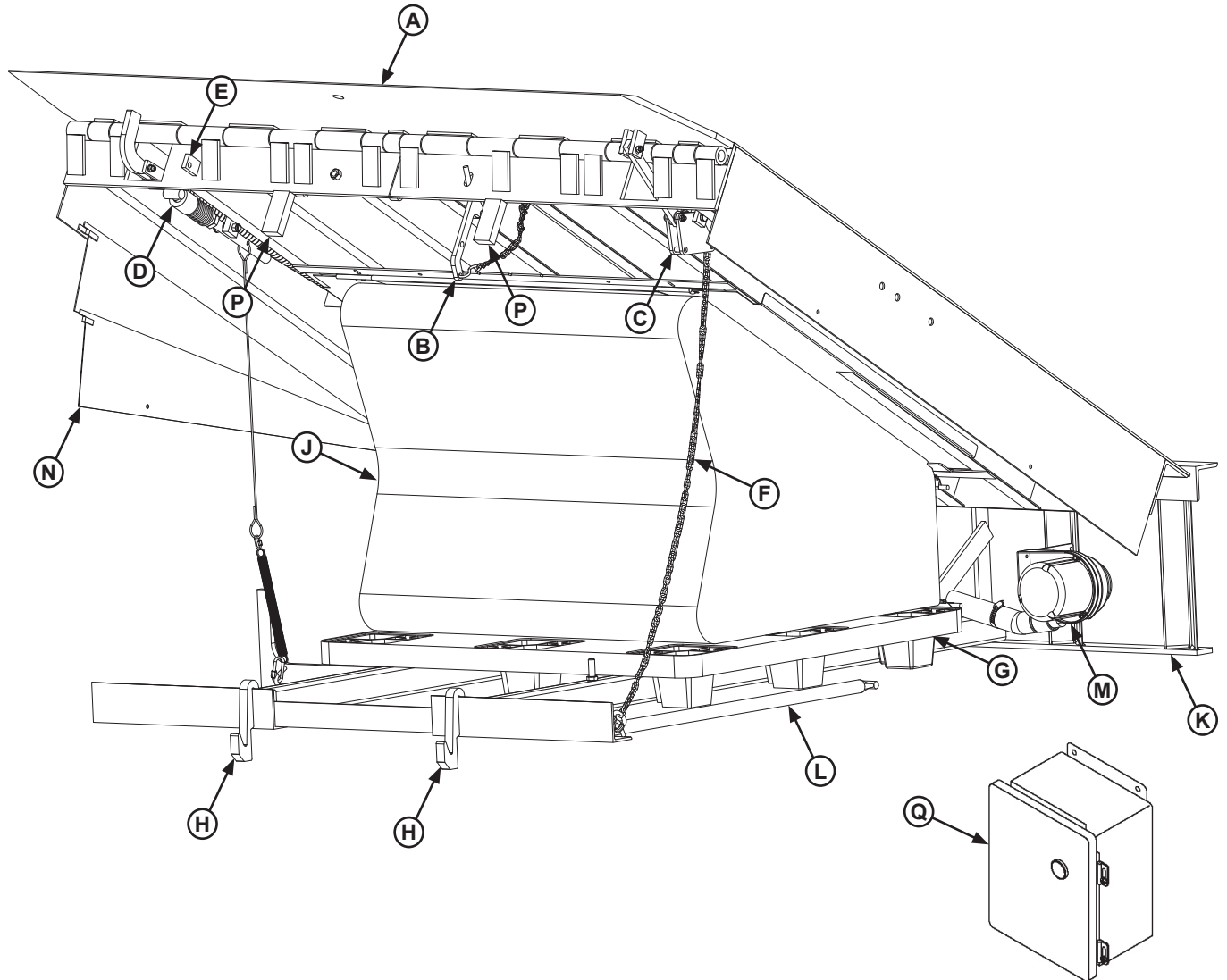

- |                          |                            |                      |                             |
|--------------------------|----------------------------|----------------------|-----------------------------|
| A — Lip                  | E — Lip Prop               | J — Air Bag          | N — Toe Guards (both sides) |
| B — Below Dock Control   | F — Lip Actuator Chain     | K — Main Frame       | P — Safety Legs             |
| C — Lip Linkage Assembly | G — Air Bag Support Pallet | L — Maintenance Prop | Q — Control Box*            |
| D — Lip Latch Assembly   | H — Lip Keepers            | M — Blower Motor     |                             |

\*Control box appearance may vary depending on options.

# INSTALLATION

## Installation Precautions

### **DANGER**

It is recommended and good safety practice to use an additional means to support the dock platform and lip anytime when physically working in front of or under the dock leveler. This additional means may include, but is not limited to a boom truck, fork truck, stabilizing bar or equivalent.

### **WARNING**

Always post safety warnings and barricade the work area at dock level and ground level to prevent unauthorized use of the dock leveler before installation is complete.

A hard hat or other applicable head protection should always be worn when working under or around a dock leveler.

Always stand clear of platform lip when working in front of the dock leveler.

### **WARNING**

DO NOT grind or weld if hydraulic fluid or other flammable liquid is present on the surface to be ground or welded.

DO NOT grind or weld if uncontained hydraulic fluid or other flammable liquid is present. Stray sparks can ignite spills or leaks near the work area. Always clean up the oil leaks and spills before proceeding with grinding or welding.

Always keep a fire extinguisher of the proper type nearby when grinding or welding.

### **CAUTION**

Only trained installation professionals with the proper equipment should install this product.

### **NOTICE**

DO NOT connect any dock equipment electrical wiring or ground connections until all welding has been completed.

DO NOT ground welding equipment to any electrical components of the dock equipment. Always ground welding equipment to the dock leveler frame, NEVER to the platform.

Failure to follow these instructions may damage the motor, wiring, and/or control panel.

### **NOTICE**

DO NOT remove the shipping bands around the dock leveler lip until instructed to do so.

This page intentionally left blank.

# INSTALLATION

## Prepare Pit

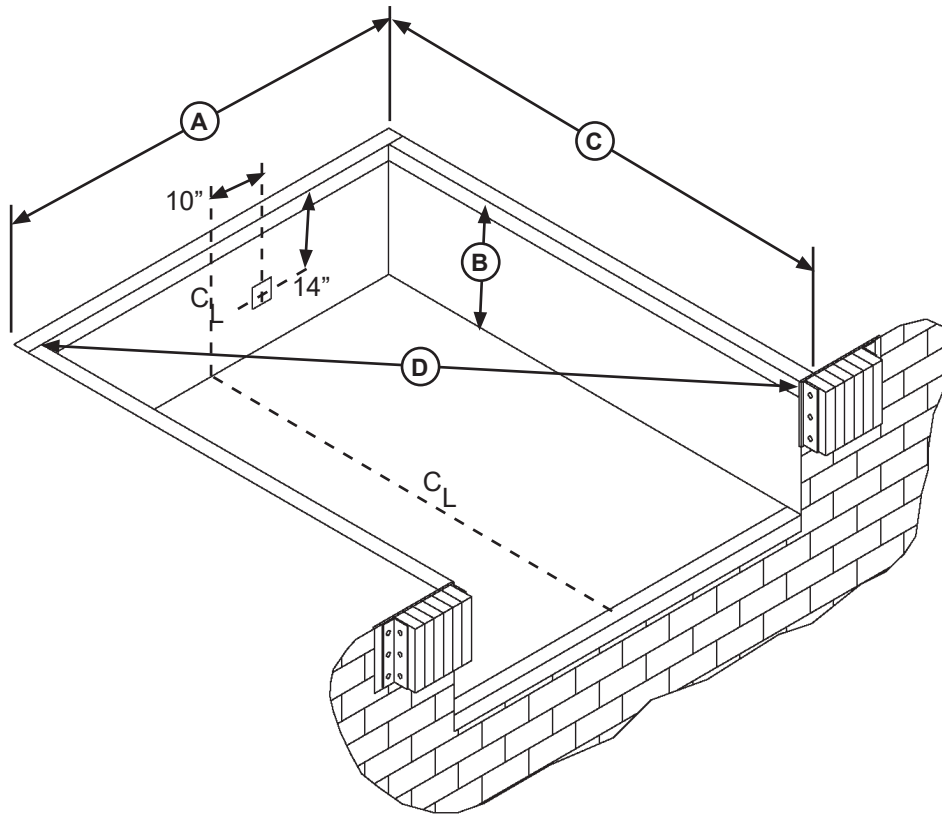

Figure 5

A—Pit Width  
(Front and Rear)

B— Dock Floor-to-Pit Floor  
(All Four Corners)

C— Pit Length  
(Both Sides of Pit)

D— Pit Corner-to-Corner  
(Top, Bottom, and Both Sides)

Before lowering the dock leveler into the pit, the following must be performed:

1. Remove all debris from the pit and sweep the pit clean.
2. Check the entire dock leveler pit for proper construction according to approved/certified pit drawings. Make sure pit is square by making the following measurements (see Figure 5):

- Measure pit width distance (**A**) at both front and rear of pit.
- Measure dock floor-to-pit floor distance (**B**) at all four corners.
- Measure pit length distance (**C**) at both sides.
- Measure corner-to-corner (diagonal) distance (**D**) at both sides. Take measurements at dock floor level and at pit floor level.

If any measurement is off by more than 1/8 in. (3.18 mm), contact Systems, LLC Technical Services before proceeding.

3. Make sure the field junction box for the dock leveler is at the correct location per pit diagrams.

## NOTICE

DO NOT remove the shipping bands (**B**) around the platform lip and leveler frame at this time. The shipping bands are needed to hold the leveler together during the installation process.

## Prepare Dock Leveler

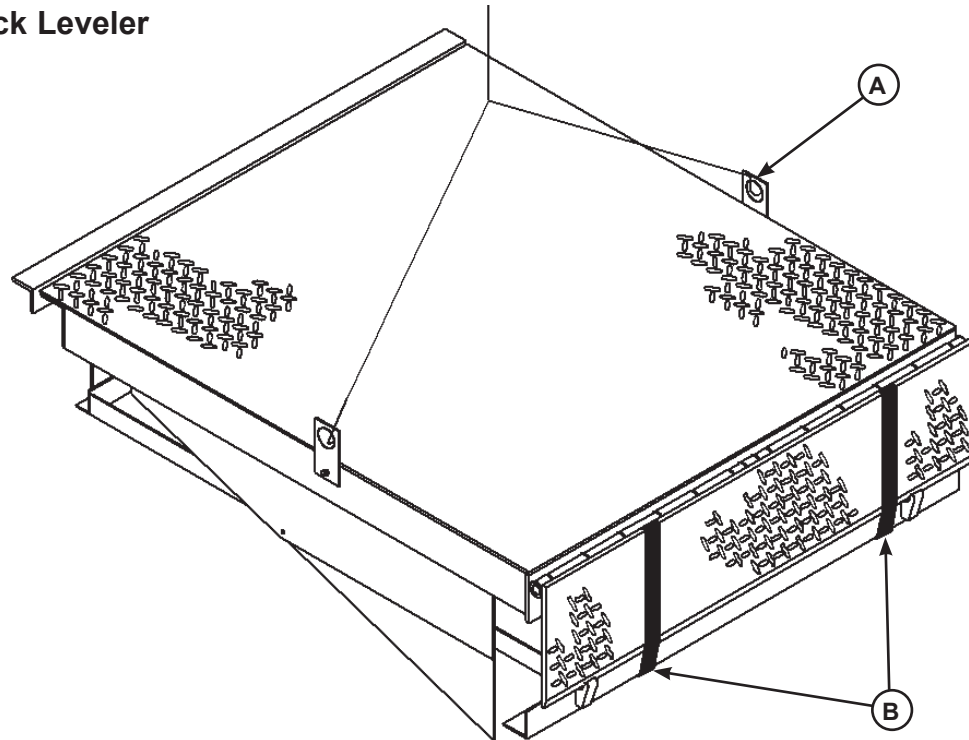

Figure 6

**A— Lifting Bracket (2 used)**

**B — Shipping Bands**

DLM dock levelers are shipped with lifting brackets (A) fastened to the platform side joists, and shipping bands (B) around the platform lip and leveler frame (see Figure 6).

1. Remove any bumpers and/or control panels that may be banded to the frame of the dock leveler.  
**Note:** Overall width of platform and lifting brackets (A) must be kept to a minimum to prevent interference between the lifting brackets and the pit walls as the dock leveler is lowered into the pit.
2. Make sure the mounting hardware of lifting brackets (A) is snug. The brackets should pivot without binding on the mounting cap screw.
3. Attach lifting chains to lifting brackets (A) and to a lifting device (i.e., hoist or fork truck) having the appropriate lifting capacity and reach.
4. Remove wood blocks that are attached to the leveler frame before putting the dock leveler into the pit.

## NOTICE

DO NOT over-tighten the lifting bracket hardware. Over-tightening can damage the weather seal, if equipped.

5. Attach a temporary switched power supply to the blower before lowering leveler into pit. Keep power cables clear of frame members, shim locations and pinch points. **DO NOT CONNECT POWER AT THIS TIME.**

6. Remove 3 plastic ties that hold the bag and bag support skid to the underside of the leveler during shipping before lowering leveler into pit (see Figure 7).

7. Proceed to “Install Dock Leveler” on Page 14.



Figure 7

# INSTALLATION

## Install Dock Leveler

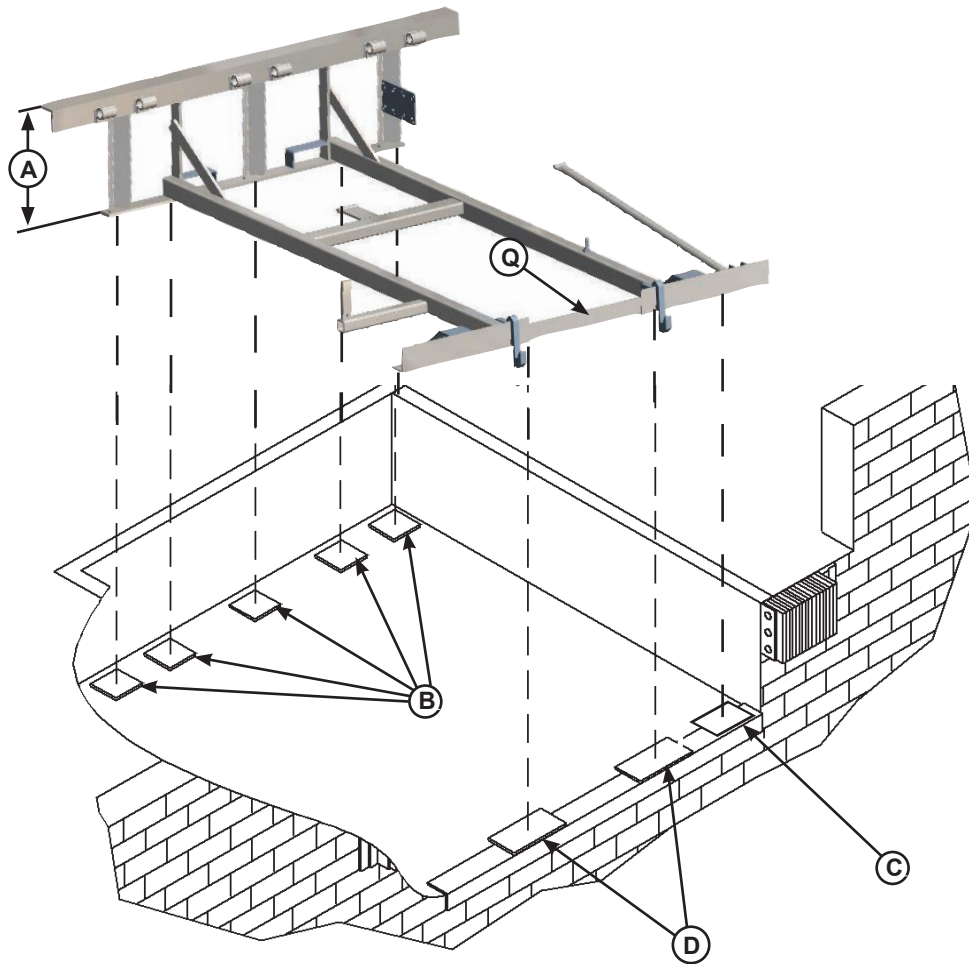

Figure 8

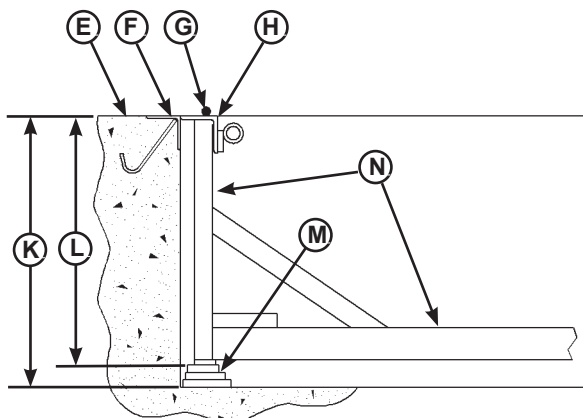

Figure 9

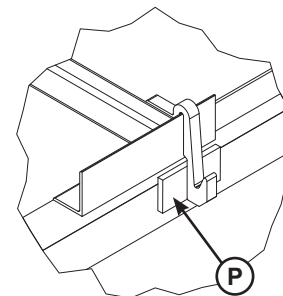

Figure 10

A— Distance (Leveler Frame Height)  
 B— Shim Locations (Under Rear Vertical Supports)  
 C— Shim Location (Under Maintenance Prop)

D— Shim Locations (Under Lip Keepers)  
 E— Dock Floor  
 F— Rear Pit Curb Angle  
 G— String  
 H— Rear Hinge Frame Angle

K— Distance (Dock Floor-to-Pit Floor)  
 L— Distance (Top of Shim Stack-to-Dock Floor)

M— Shim Stack  
 N— Dock Leveler Frame  
 P— Lip Keeper Shim (as required)  
 Q— Shipping Bar



## Install Dock Leveler (continued)

**Note:** DLM dock levelers are designed with a nominal 1/2" (12.7 mm) shimming distance to allow for pit inconsistencies.

1. Determine height of shim stack (**M**) for each shim location (**B**) by performing the following:

- a. Measure leveler frame height distance (**A**).
- b. Measure dock floor-to-pit floor distance (**K**) at each shim location (**B**). Write down the dimensions obtained at each location.
- c. Subtract distance (**A**) from distance (**K**) to obtain the shim height. Repeat for each shim location.

2. Using the results obtained in step 1, create the individual shim stacks on the pit floor at location (**B**). Build each shim stack (**M**) with the top shim having a minimum size of 4" x 4" (101.6 mm x 101.6 mm) and each successive lower shim being larger so the shims can be welded together using a fillet weld. If using offset method, make sure load is over center of shim stack, NOT over the edge. DO NOT use straight method. See Figure 11.

## NOTICE

The minimum size of the shim that contacts the leveler frame (i.e. the top shim of each shim stack) must be at least 4" x 4" (101.6 mm x 101.6 mm) to support the full width of the frame rail and to provide a shelf for a fillet weld.

Use the thickest shim stock possible for stability and weld penetration purposes. DO NOT use multiple layers of 1/8 in. (3.2 mm) or thinner shim stock.

**Note:** To assist in obtaining an accurate measurement of distance (**L**), use a string (**G**) pulled tight across the pit opening, directly over the shim locations.

3. Verify that each shim stack is at the correct height by measuring distance (**L**) [top of shim stack (**M**) to dock floor]. Distance (**L**) must equal the dock leveler height (**A**).

4. Put a 1/4 in. (6.4 mm) thick shim at locations (**C** and **D**).

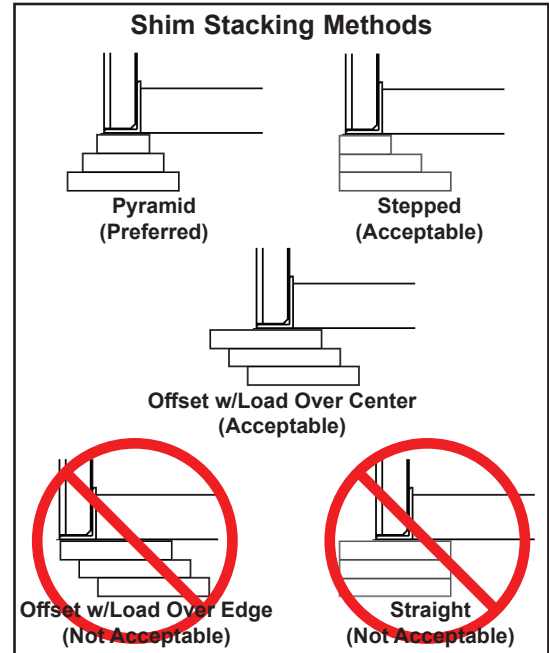

Figure 11

**Note:** A 1/4" (6.4 mm) thick shim at locations (**C** and **D**) are used only as a starting point. The final shim stack height will be determined after dock leveler is lowered into the pit.

5. Using an appropriate lifting device connected to the lifting brackets, lower dock leveler into the pit so rear hinge frame angle (**H**) is tight against rear pit curb angle (**F**) across full width of the leveler frame.

## WARNING

The dock leveler is heavy. Use a lifting device and chains with the appropriate lifting capacity and reach.

Always use the lifting brackets provided with the unit whenever lowering or lifting a dock leveler into or out of a pit.

6. Allow rear of dock leveler to rest on the rear shims while keeping the front of the dock leveler level with the dock floor.

7. Add shims at front shim locations (**C** and **D**) so front of dock leveler will stay level with dock floor when leveler is resting fully on shims.

# INSTALLATION

## Install Dock Leveler (continued)

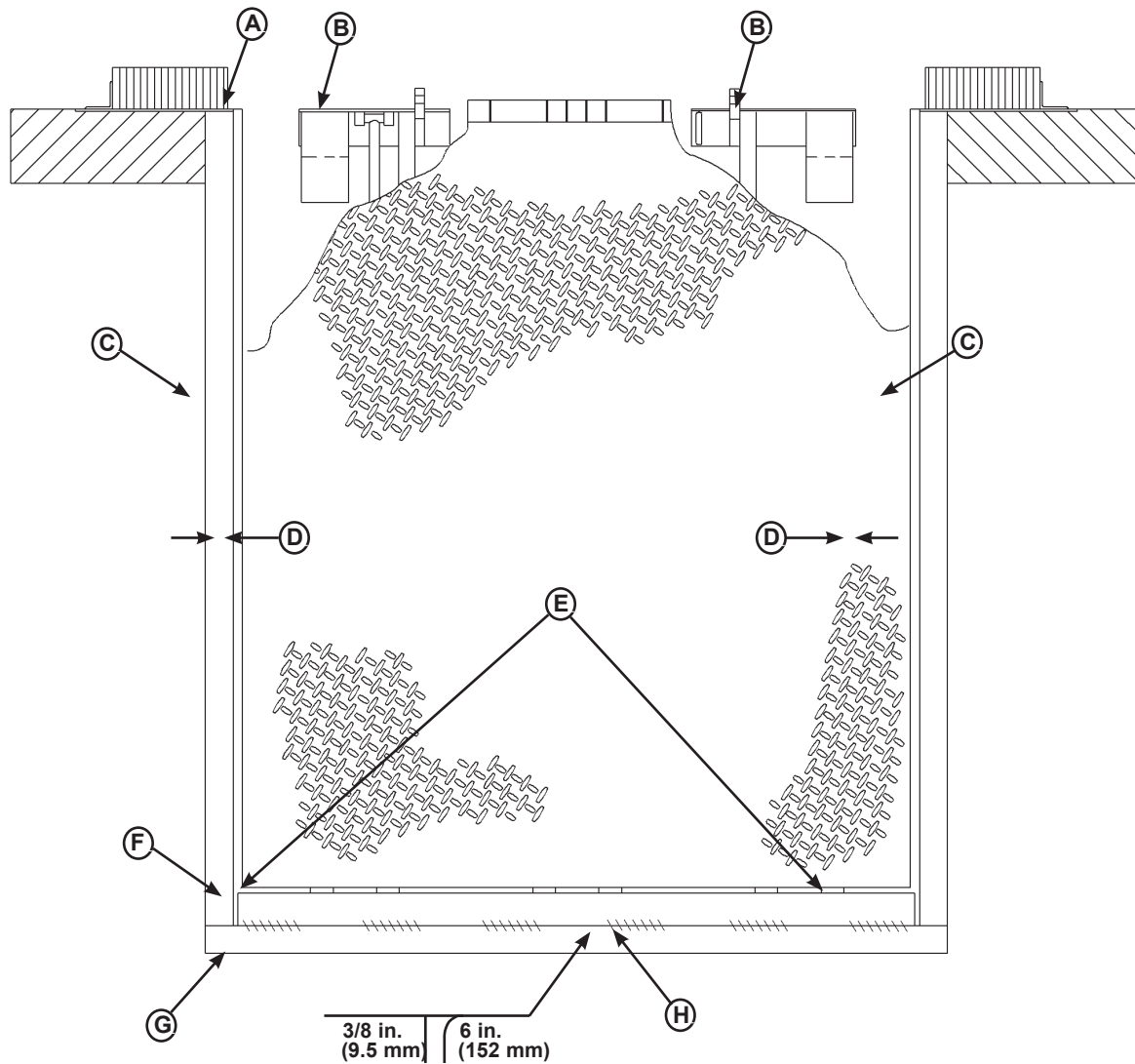

**Figure 12**

- |                       |                                  |                           |   |
|-----------------------|----------------------------------|---------------------------|---|
| A— Front of Dock Pit  | C— Side Pit Curb Angle           | E— Pry Locations          | G— Rear Pit Curb Angle                        |
| B— Dock Leveler Frame | D— Gap [3/4 in. (19 mm) Minimum] | F— Rear Hinge Frame Angle | H— Flare Bevel Weld, Typical (To Fit Spacing) |

8. With rear hinge frame angle (F) tight against rear pit curb angle (G), perform/check the following:

- Pry between the platform and rear hinge frame angle at locations (E) to make sure rear edge of platform is parallel to the rear hinge frame angle (F).
- Gap (D) must exist equally along both sides of leveler so weather seal (if equipped) will not bind during dock leveler operation.

9. If gap (D) cannot be obtained equally at both sides of leveler, grind or add material at the rear edge of rear hinge frame angle (F) as needed.

10. Allow the dock leveler to rest fully on the shim stacks. Check that a smooth and level transition exists between the dock floor and the dock leveler platform. Add or remove shims as necessary until a smooth transition is obtained.

11. If leveler cannot be squared and/or made level as instructed in steps 8-10, contact Systems, LLC Technical Services.

## Install Dock Leveler (continued)

### **WARNING**

DO NOT use the maintenance prop to support the raised platform until the maintenance prop has been properly shimmed and welded. The shims must be welded to each other, and also to the leveler frame.



Figure 13



Figure 14

### **NOTICE**

DO NOT weld continuously along the full length of the rear hinge frame angle. This can put unnecessary stress on the leveler components, causing the leveler to malfunction and shorten the lifespan of the affected components.

12. With the leveler square in the pit and flush with the surrounding dock, remove the banding on the lip of the leveler. Manually raise the platform.

13. Connect the blower motor to the temporary power supply.

14. Slowly raise the platform with the blower motor. Check for binding as platform is being raised.

15. If binding occurs, lower the platform. Reposition leveler and/or add or remove shims as necessary. Slowly raise platform again. If platform still binds, contact Technical Services for further instructions.

16. Shim and weld the maintenance prop:

a. Install shims under maintenance prop (**B**) where prop attaches to leveler frame. Make sure prop is solidly shimmed.

b. Raise maintenance prop (**B**) to the service (upright) position and lock prop in this position using an OSHA approved locking device.

c. Proceed to step 23.

17. Disconnect power supply from motor.

18. Remove air bag and support pallet from the leveler by disconnecting air bag positioning rods from hooks on the underside of platform as shown in Figure 13, and removing the band clamp from the motor coupler as shown in Figure 14.

19. Remove blower motor from the leveler by unbolting from the frame, or wrap the blower with a fireproof blanket to protect from weld sparks and splatter.

20. With the rear hinge frame angle (**F**) tight against the rear pit curb angle (**G**), weld the rear hinge frame angle (**F**) to the rear pit curb angle (**G**) using a 3/8 in. (9.5 mm) flare bevel skip weld — each weld being 6 in. (152 mm) long.

- Start at each end with a 6 in. (152 mm) long weld. Space all the other welds out evenly, leaving approximately 6 in. (152 mm) space between each weld.

**Note:** Figure 12 shows a typical weld pattern. The weld pattern will vary slightly depending on size of dock leveler.

# INSTALLATION

## Install Dock Leveler (continued)

21. Weld front of dock leveler frame (**B**, page 16) to shims located under the keepers, then weld the shims to the front pit curb steel.

### **WARNING**

Make sure the platform is properly supported in the raised position before entering the pit to finish weld the shims.

22. Finish weld all shims using a fillet weld.

- Weld all shims within each shim stack to each other, then weld the shim stack to the leveler frame.
- Weld the front leveler frame shim stacks to the front pit curb steel.

23. If present, weld the lip keeper shims (**P**, page 14) to the front pit curb steel.

24. Remove the Shipping Bar (**Q**, page 14) by grinding the tack welds that hold it in place during transport.

25. Install the dock bumpers as required.

26. When all welding has been completed, paint all the welds and shims.

27. Re-install the air bag, air bag support pallet and blower motor (if removed in step 19).

28. Proceed to “Install Control Panel” on Page 20.

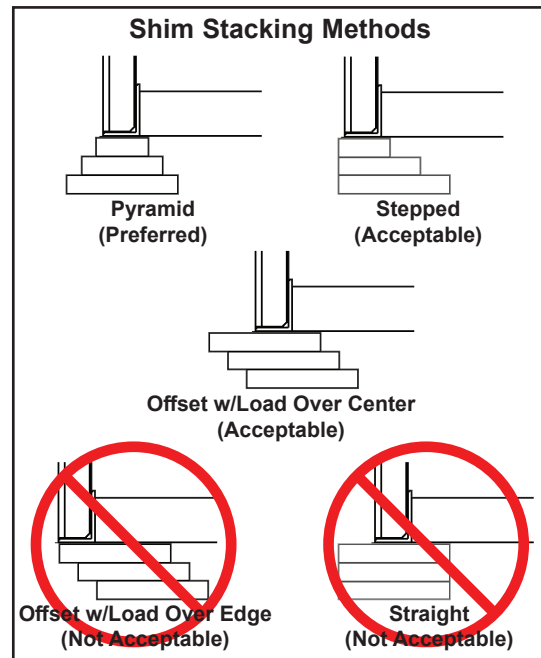

Figure 15

This page intentionally left blank.

# INSTALLATION

## Install Control Panel and Wiring

### **! DANGER**

Make sure that the power source has been locked out and tagged according to OSHA regulations and approved local electrical codes.

### **! WARNING**

A hard hat or other applicable head protection should always be worn when working under or around a dock leveler.

Always stand clear of platform lip when working in front of the dock leveler.

### **! CAUTION**

All electrical work — including the installation of the disconnect panel, control panel, and final connections to the pit junction box — must be performed by a certified electrician and conform to all local and applicable national codes.

### **NOTICE**

DO NOT connect any dock equipment electrical wiring or ground connections until all welding has been completed.

DO NOT ground welding equipment to any electrical components of the dock equipment. Always ground welding equipment to the dock leveler frame, NEVER to the platform.

Failure to follow these instructions may damage the motor, wiring, and/or control panel.

### **NOTICE**

Where indicated, all components must be connected to a SAFETY EARTH GROUND that conforms to the 1999 National Electrical Code Section 250-50 section (a) or section (c) for a grounding electrode system.

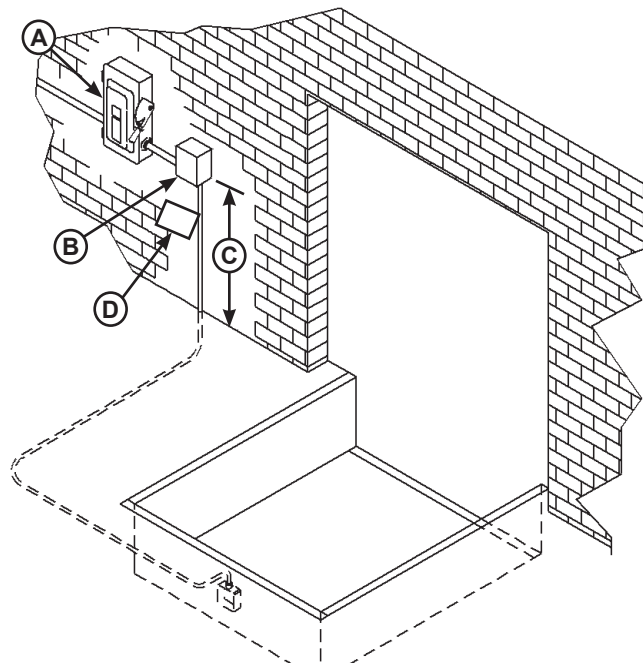

**Figure 16**

**A**— Disconnect Panel (provided by others)      **C**— Distance, 48 in. (1219 mm)  
**B**— Control Panel      **D**— Placard

1. Mount the control panel (**B**) so bottom of control panel-to-dock floor distance is 48 in. (1219 mm, **C**).
2. Install electrical disconnect panel (**A**) if not already installed (provided by others). It is recommended to locate disconnect panel adjacent to control panel (**B**).
3. Install and connect the control wiring as shown in installation drawings.
4. Connect the control wiring to the field wires in the dock equipment junction boxes. Refer to the electrical diagrams supplied with the dock equipment.

**Note:** When installing electrical controls in a temperature-controlled environment, the installer must determine an appropriate means to isolate/prevent thermal and vapor transfer through electrical conduit where conduit routing crosses temperature zones. Systems, LLC is not responsible for any damage due to moisture collecting inside the control panel caused by improper isolation/prevention of thermal and vapor transfer through the conduit. Refer to Tech Service Bulletin 19-053 for more information.

5. Install placard (**D**). Make sure placard is in plain view of dock leveler and/or vehicle restraint operations. Suggested placement of placard is near control box attached to electrical conduit by using nylon cable tie. See page 22.

## Standard Control Panel Wiring

TABLE 1 RECOMMENDED FIELD WIRE SIZE			
CIRCUIT LENGTH			
50 FT	75 FT	125 FT	175 FT
10 AWG	8 AWG	6 AWG	4 AWG

TABLE 2	
TOTAL 1 PHASE FLA = 11.8 A	

TABLE 3 MOTOR NAMEPLATE DATA MOTOR LOCATED AT DOCK LEVELER	
VOLTAGE	FLA
115 V	11.8 A

CUSTOMER SUPPLIED  
115 V, 1 PHASE, 60 HZ  
FROM BRANCH CIRCUIT DISCONNECT SWITCH  
& OVERCURRENT DEVICE BY OTHERS.  
SELECT DISCONNECT SWITCH &  
OVERCURRENT DEVICE PER THE NEC.  
LOCATE A DISCONNECT SWITCH  
NEXT TO THE ENCLOSED STARTER.  
DUAL ELEMENT TIME DELAY FUSES  
MUST BE USED FOR BRANCH  
CIRCUIT PROTECTION.  
SEE TABLES 1, 2 AND 3

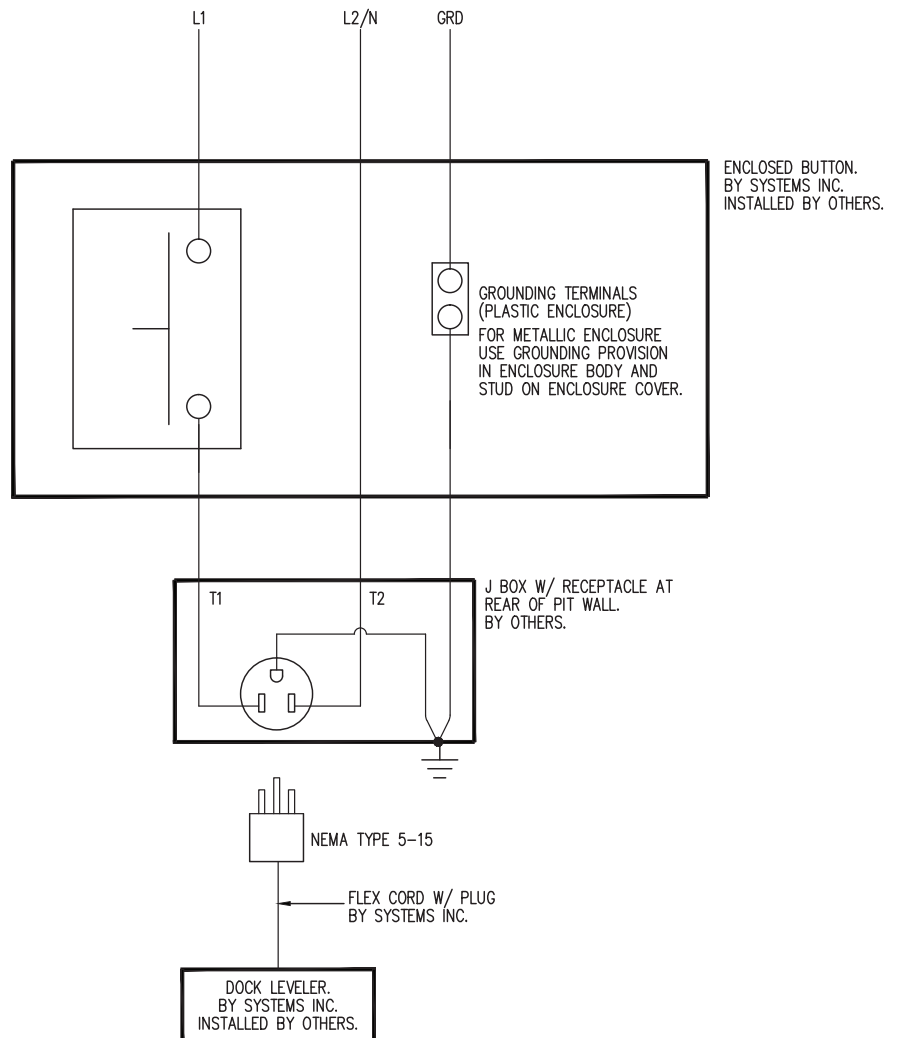

NOTE
1. ALL WIRES, UNLESS INDICATED OTHERWISE, BY OTHERS.
2. ALL CONDUIT, UNLESS INDICATED OTHERWISE, BY OTHERS.
3. ALL WIRE CONNECTIONS BY OTHERS.

# INSTALLATION

## Placard Installation Instructions

- Owner/Users are responsible for the installation and placement of product placards.
- Make sure placard is in plain view of dock leveler and/or vehicle restraint operations.
- Suggested placement of placard is near control box attached to electrical conduit by using nylon cable tie. If there is no control box present, mount placard on wall to the immediate left of leveler at eye level.

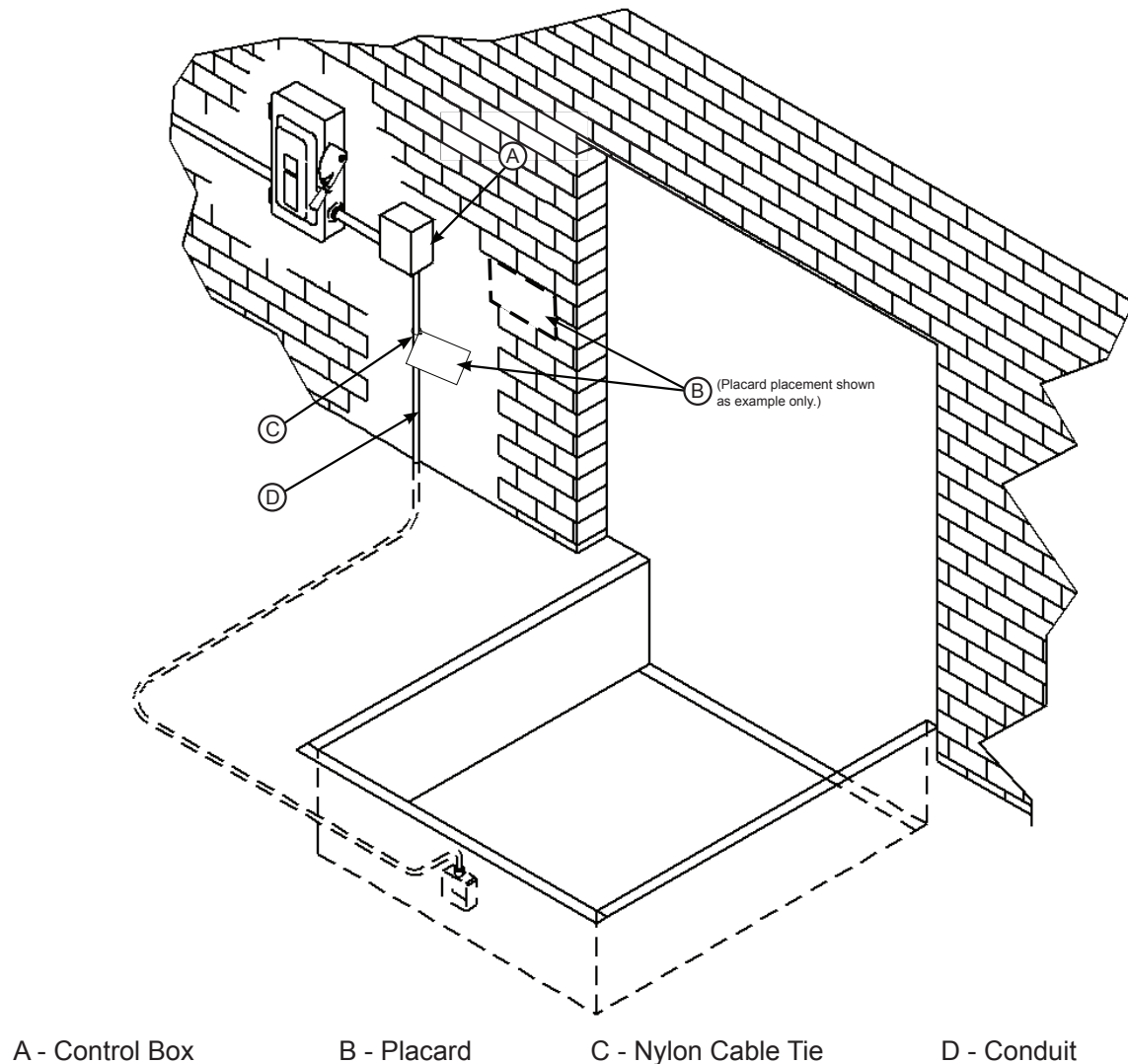

Figure 17



## Put New Dock Leveler Into Service

### **WARNING**

A hard hat or other applicable head protection should always be worn when working under or around a dock leveler.

Always stand clear of platform lip when working in front of the dock leveler.

1. Disconnect the external lifting device and chains from the lifting brackets.
2. Check that the leveler is flush with the dock floor and that the platform lip contacts both lip keepers evenly.

**Note:** If an excessive transition exists between the dock floor and leveler and/or lip does not contact both lip keepers evenly, contact Systems, LLC Technical Services for further instructions.

3. Turn the main electrical power ON.
4. Press the RAISE button and hold until leveler platform is fully raised and the lip extends.
5. Release the RAISE button. If no transport vehicle present at the dock, the platform will lower to the below-dock safety legs and the lip will fold.

**Note:** If a transport vehicle is present, the platform will lower until the lip rests on the transport vehicle's bed.

6. When the platform lowers to the below-dock safety legs, the lip will fold. Press and hold the RAISE button until the lip rises just enough to clear the lip keepers, then release the RAISE button to allow the platform to lower to the cross-traffic (stored) position (lip engages lip keepers).

7. Perform steps 4-6 at least four times to ensure proper operation with no binding.

8. Raise the platform fully. Hold the platform at this position by pressing the RAISE button and move the maintenance prop to the service (upright) position. Release the RAISE button to allow the platform to lower until it is resting on the maintenance prop.

### **DANGER**

Unless the dock leveler is equipped with a tethered remote, two people are required to engage the maintenance prop: one person to operate the unit, the other person to engage the maintenance prop.

In addition, it is recommended and good safety practice to use an additional means to support the dock platform and lip anytime when physically working in front of or under the dock leveler. This additional means may include, but is not limited to a boom truck, fork truck, stabilizing bar or equivalent.

9. Secure the maintenance prop with the maintenance prop lock-out.

10. With the maintenance prop supporting the platform, remove the lifting brackets.

11. Support the toe guards on each side of the platform, then remove the cotter pin used in shipping and carefully release the toe guards.

12. Release the maintenance prop by unlocking the lock-out.

13. Press the RAISE button and hold until the maintenance prop drops to its stored position. Release the RAISE button and allow the platform to lower fully.

# OPERATION

## Operational Precautions

### **DANGER**

Stay clear of dock leveler and vehicle restraint when transport vehicle is entering or leaving dock area.

DO NOT move or use the dock leveler or restraint if anyone is under or in front of leveler.

Keep hands and feet clear of pinch points. Avoid putting any part of your body near moving parts.

### **WARNING**

Only trained personnel should operate the dock leveler.

DO NOT use a broken or damaged dock leveler. Make sure proper service and maintenance procedures have been performed on leveler before using.

Transport vehicle wheels must be chocked unless a vehicle restraint is used. Never remove the wheel chocks until loading/unloading is finished and transport driver has been given permission to leave.

Make sure platform lip rests on the transport vehicles bed with at least 4 in. (102 mm) of overlap.

Maintain a safe distance from side edges of leveler during the loading/unloading process.

### **WARNING**

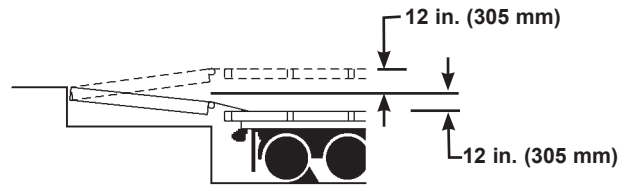

The DA pneumatic dock leveler is designed to compensate for a maximum  $\pm 12$  in.\* (305 mm) of height difference between the loading dock and the transport vehicle's bed. DO NOT use the dock leveler if the transport vehicle's bed is more than 12 in. (305 mm) higher or lower than the dock floor.

\*Service height may vary with design specifications

DO NOT overload the dock leveler.

DO NOT operate any equipment while under the influence of alcohol or drugs.

DO NOT leave equipment or material unattended on the dock leveler.

This page intentionally left blank.

# OPERATION

## Operating Instructions

### Ramp Loading/Unloading

1. Before activating dock leveler, check to make sure the transport vehicle is positioned squarely against dock bumpers. Ensure lip will avoid contact with transport vehicle frame, sides and cargo during dock leveler activation. If contact is likely or observed, reposition transport vehicle.
2. Instruct driver to remain at the dock until the loading or unloading process has been completed.
3. Chock the transport vehicle wheels, or use a vehicle restraint if available.
4. Extend the dock leveler onto the transport vehicle as follows:
  - a. Raise the platform by pressing and holding the RAISE button.
  - b. Hold the RAISE button until the lip is fully extended, then release the RAISE button. The platform will lower until the lip is resting on the transport vehicle bed.
  - c. Make sure that the lip is fully extended and supported on the transport vehicle along the entire width of the platform, with at least 4 in. (102 mm) of lip contacting the transport vehicle bed. See Figure 18.

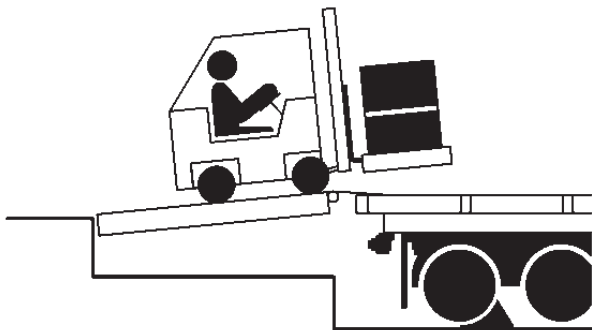

Figure 18

5. Proceed with loading or unloading the transport vehicle.
6. When loading or unloading is finished, raise the platform by pressing and holding the RAISE button until the lip folds enough to land in the lip keepers, then release the RAISE button. The platform will return to the cross-traffic position.

7. Remove chocks from transport vehicle wheels, or release the vehicle restraint if used.
8. Indicate to driver that the transport vehicle may leave the dock.

### Below Dock Loading/Unloading

**Note:** Below Dock Loading/Unloading follows the same process as Ramp Loading/Unloading, but requires use of the below dock control ring.

1. Follow steps 1-3 in "Ramp Loading/Unloading."
2. Extend the dock leveler onto the transport vehicle as follows:
  - a. Raise the platform by pressing and holding the RAISE button.
  - b. Hold the RAISE button until the lip is fully extended, then release the RAISE button.

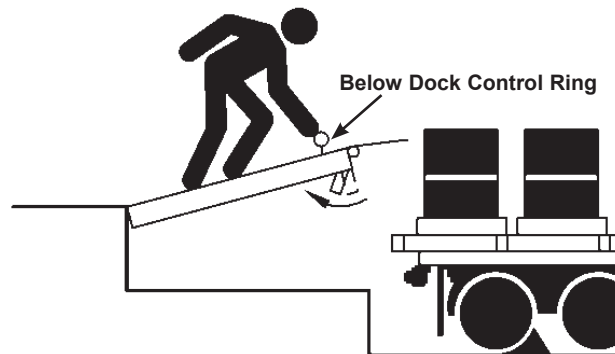

Figure 19

- c. Walk out on the leveler, pull and hold the below dock control ring (located in the recess at the front of the platform). This will cause the safety legs to fold allowing the leveler to lower to the full below dock position. See Figure 19.
  - d. Allow the platform to drift down to the full below-dock position.
  - e. Make sure that the lip is fully extended and supported on the transport vehicle along the entire width of the platform, with at least 4 in. (102 mm) of lip contacting the transport vehicle bed.
3. Continue with steps 5-8 in "Ramp Loading/Unloading."

## Operating Instructions (continued)

### End Loading/Unloading

1. Before activating dock leveler, check to make sure the transport vehicle is positioned squarely against dock bumpers. Ensure lip will avoid contact with transport vehicle frame, sides and cargo during dock leveler activation. If contact is likely or observed, reposition transport vehicle.
2. Instruct driver to remain at the dock until the loading or unloading process has been completed.
3. Chock the transport vehicle wheels, or use a vehicle restraint if available.

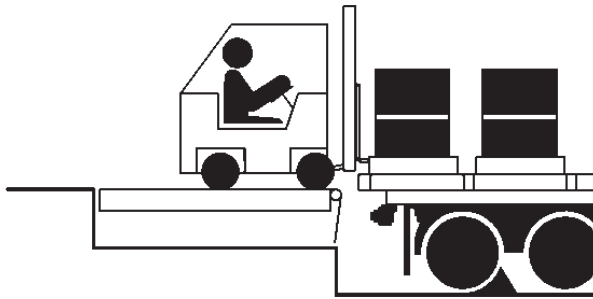

Figure 20

4. If transport vehicle bed is at or above dock floor level, leave leveler at the cross-traffic position and proceed with loading or unloading (see Figure 20). If transport vehicle bed is below the dock floor level, continue with Step 5.
5. Press RAISE button to position the platform high enough to clear the lip keepers, but not high enough to extend the lip.
6. Walk out on the leveler, pull and hold the below dock control ring (located in the recess at the front of the platform). This will cause the lip to extend away from the lip keepers and the safety legs to fold allowing the leveler to lower to the full below dock position. See Figure 18.
7. When the platform lip clears the lip keepers, continue to hold the pull chain as the leveler lowers to the below-dock position. The platform will drift down to the full below-dock position.
8. Allow the platform to drift down to the full below-dock position.



Figure 21

9. Proceed with loading or unloading (see Figure 21).

**Note:** When end unloading is finished and access to the rest of the transport vehicle is still required, the platform lip will need to be extended. See Ramp Loading/Unloading Instructions on page 24 for further instructions.

10. When end loading or unloading is finished, raise the platform by pressing and holding the RAISE button until the lip folds enough to land in the lip keepers, then release the RAISE button. The platform will return to the cross-traffic position.
11. Remove chocks from transport vehicle wheels, or release the vehicle restraint if used.
12. Indicate to driver that the transport vehicle may leave the dock.

# MAINTENANCE

## Maintenance Precautions

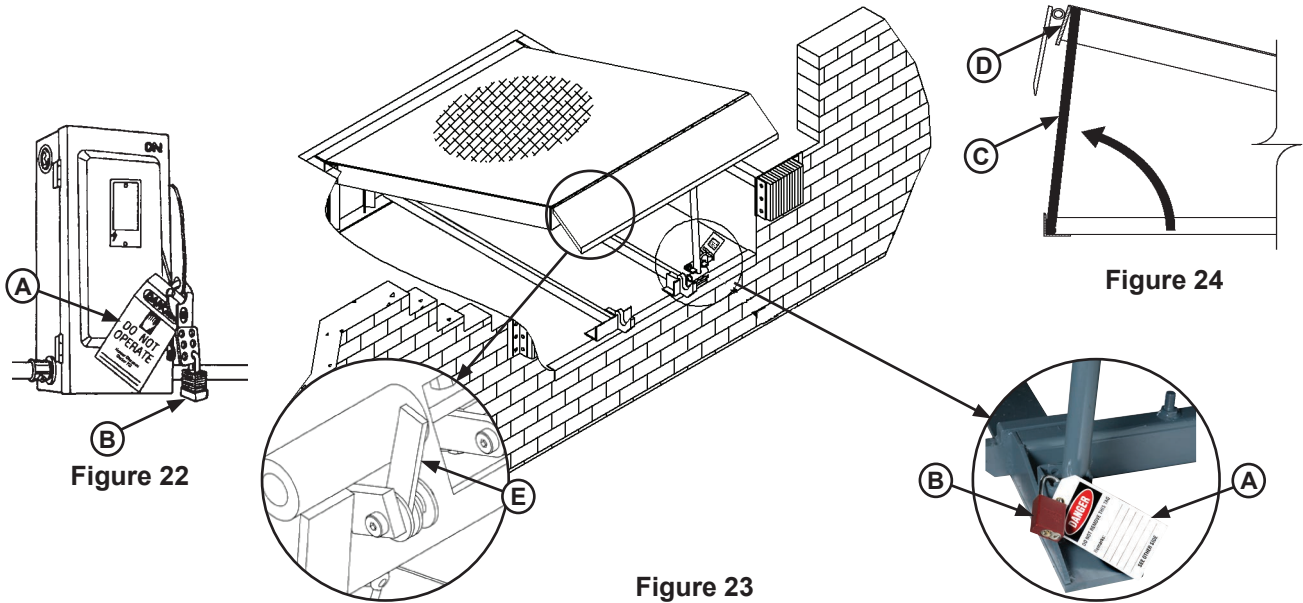

Figure 22

Figure 23

Figure 24

A - Tag Out Device

B - Lock Out Device

C - Maintenance Prop

D - Header

E - Lip Prop

### **! DANGER**

Unless the dock leveler is equipped with a tethered remote, two people are required to engage the maintenance prop: one person to operate the unit, the other person to engage the maintenance prop.

In addition, it is recommended and good safety practice to use an additional means to support the dock platform and lip anytime when physically working in front of or under the dock leveler. This additional means may include, but is not limited to a boom truck, fork truck, stabilizing bar or equivalent.

When working with electrical or electronic controls, make sure that the power source has been tagged (A) and locked out (B) according to OSHA regulations and approved local electrical codes (see Figure 22).

Whenever maintenance is to be performed under the dock leveler platform, support the platform with maintenance prop (C). Position the maintenance prop behind front header plate (D) while staying clear of the lip. Position the lip prop (E) under the lip to hold it in place. Lock the maintenance prop in the service (upright) position using an OSHA approved lockout device\* (B) and tag out device\* (A). See Figures 23 and 24.

### **! WARNING**



Always post safety warnings and barricade the work area at dock level and ground level to prevent unauthorized use of the unit before maintenance is complete.

Only the person servicing the equipment should have the capability to remove the lockout devices. The tag out devices\* must inform that repairs are in process and clearly state who is responsible for the lockout condition.

### **! WARNING**

A hard hat or other applicable head protection should always be worn when working under or around a dock leveler.

Always stand clear of platform lip when working in front of the dock leveler.

\* Refer to OSHA regulations 1910.146. Confined Space and 1910.147. Lockout/Tagout

This page intentionally left blank.

# MAINTENANCE

## Periodic Maintenance

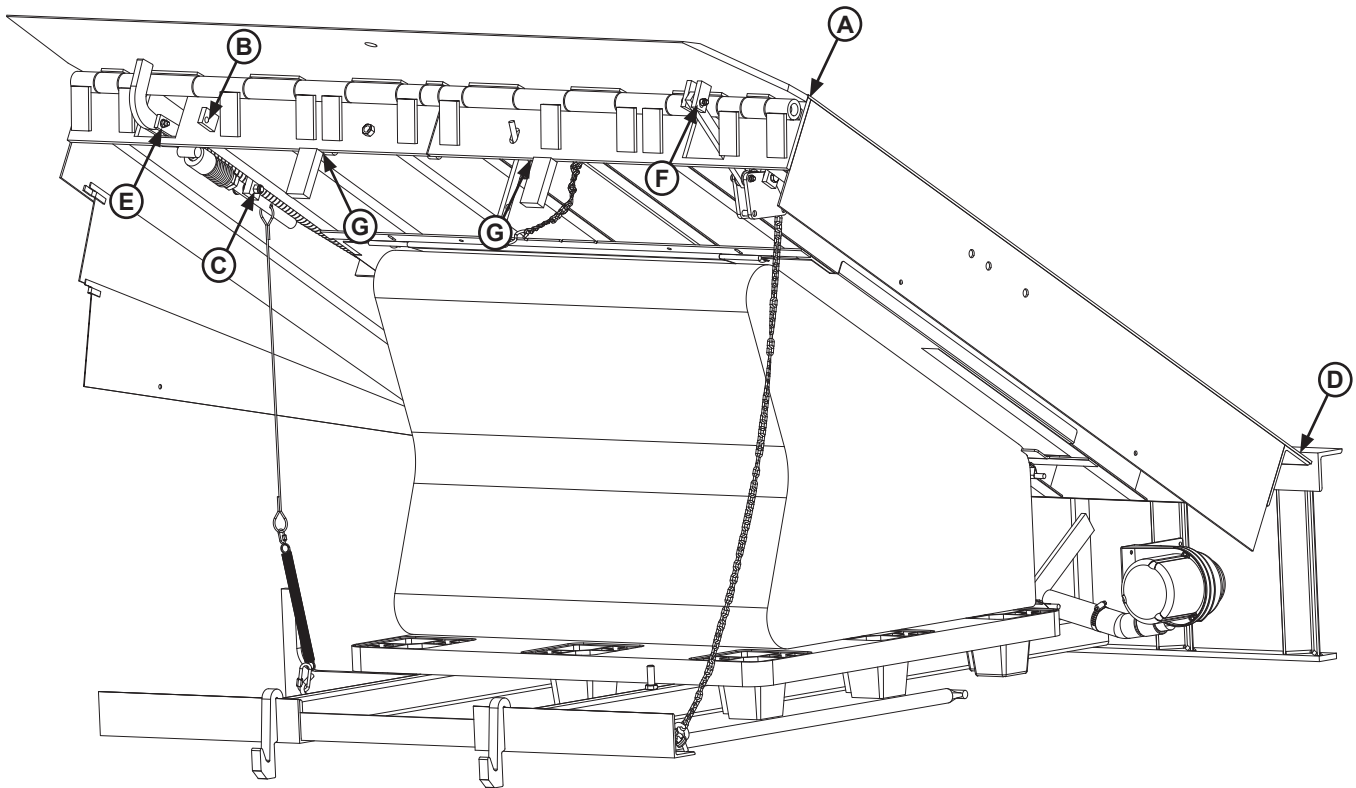

**Figure 25**

A - Lip Hinge Area

C - Lip Link Pivots

E - Lip Assist Pin

G - Safety Leg Linkage Pivots

B - Lip Maintenance Prop Pivot

D - Platform Hinge Area

F - Lip Linkage Pivot

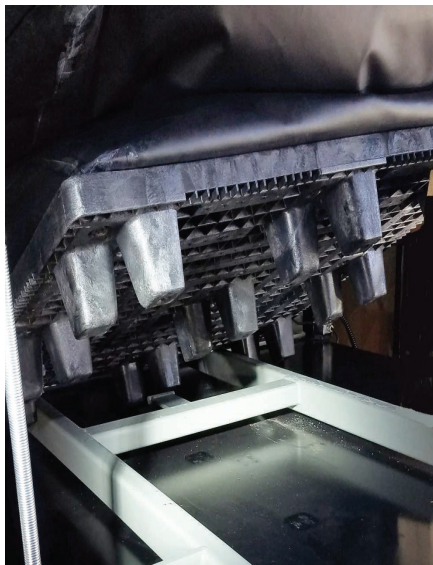

**Figure 26**

Under platform service



**Figure 27**

Air Filter, service under rear of platform



## Weekly Maintenance

- Operate the dock leveler through the complete operating cycle to maintain lubrication.

**Note:** To thoroughly inspect the platform hinge area, put the platform in the full below-dock position.

- Inspect the platform hinge and the lip hinge areas. The hinge areas must be kept free of dirt and debris. Build-up of foreign material in the hinge areas will cause abnormal operation.
- Inspect the area under the platform, around and under the air bellows (see Figure 26). Look for cracks in the welds or damage. Build-up of foreign material in this area may damage air bellows components, causing abnormal operation.
- Inspect warning decals and placards. Replace if damaged or missing.
- Check air bag and seams for punctures or abrasions. Inspect hold-down rods and hardware.
- Clean leveler pit to prevent air bag puncture.

### **DANGER**

If air bag is punctured or leaking, do not attempt to patch or repair air bag! Contact Systems, LLC for a replacement.

## Quarterly Maintenance

- Complete Weekly Maintenance.
- Inspect the following for damage/abnormal wear:
  - Check welds for cracks.
  - Lip hinge pins and rear hinge pins.
  - Check full range toe guards (if equipped) for free movement.
  - Inspect blower motor housing, filter, hose and hardware.
  - Control box and conduit for damage.
  - Bumpers for more than 1" of wear. Replace worn, loose, damaged or missing bumpers.
  - Side and rear weather seals (if equipped).
- Clean blower motor air filter (see Figure 27).

- Lubricate the following areas with light weight machine oil:
  - (A)— Lip hinge area unless equipped with grease fittings (apply oil to the top of the entire length of lip hinge when platform is at the full below-dock position and lip is folded)
  - (D)— Platform hinge area (apply oil to top of all platform hinges when platform is at the full below-dock position)

NOTE: Apply grease to lip hinge grease fittings if equipped.

(B)— Lip maintenance prop pivot

(C)— Lip link pivots

(F)— Lip Linkage assembly pivot

(G)— Safety leg linkage pivots

- Lubricate the following areas with white lithium grease:

(E)— Lip assist rod pin

### **NOTICE**

Failure to properly lubricate the dock leveler will cause abnormal operation of the leveler.

# ADJUSTMENTS

## Adjust Lip Latch & Lip Actuator Spring Tension

### **DANGER**

Unless the dock leveler is equipped with a tethered remote, two people are required to engage the maintenance prop: one person to operate the unit, the other person to engage the maintenance prop.

In addition, it is recommended and good safety practice to use an additional means to support the dock platform and lip anytime when physically working in front of or under the dock leveler. This additional means may include, but is not limited to a boom truck, fork truck, stabilizing bar or equivalent.

### **WARNING**

When service under the dock leveler is required, always lock all electrical disconnects in the OFF position after raising the platform and engaging the maintenance prop.

Always post safety warnings and barricade the work area at dock level and ground level to prevent unauthorized use of the dock leveler before maintenance is complete.

A hard hat or other applicable head protection should always be worn when working under or around a dock leveler.

Always stand clear of platform lip when working in front of the dock leveler.

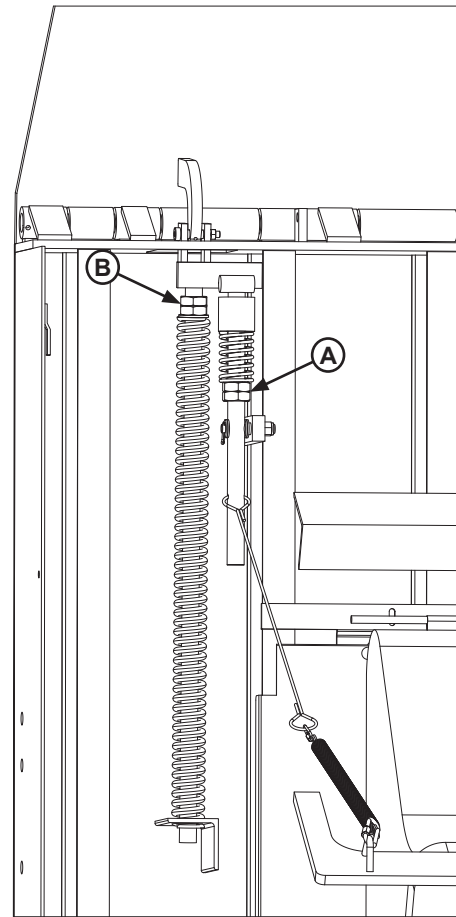

**Figure 28**

**A— Lip Latch Spring Adjustment**

**B— Lip Actuator Spring Adjustment**

## Adjust Lip Latch & Lip Actuator Spring Tension (continued)

The lip latch and lip actuator spring tension are set at the factory and should not require additional adjustment unless parts have been replaced.

Unlike mechanical levelers, the lip will not immediately begin to fold as the platform returns to the stored position.

After the platform is fully raised, and the lip extends, the lip latch is designed to hold the lip in the extended position until the platform drifts down to the below dock position.

The lip will automatically fold when the platform is resting on the safety legs in the below dock position.

If the lip extends fully, but does not remain extended, check proper engagement of the lip latch before adjusting the lip latch spring.

If the lip does not extend fully, check air bellows and lines for possible leaks before adjusting the lip actuator spring.

### Lip Latch Spring Tension

**Note:** Use two-turn increments when adjusting lip assist spring. Check lip operation after each adjustment. Repeat until proper operation is obtained.

Adjust lip latch spring tension as follows:

1. Loosen jam nut on **(A)**.
2. To increase spring tension, turn adjustment nut on **(A)** clockwise.
3. To decrease spring tension, turn adjustment nut on **(A)** counterclockwise.
4. Tighten jam nut **(A)**.
5. Recheck operation of platform and lip. Readjust lip latch spring tension as needed.

### Lip Actuator Spring Tension

**Note:** Use two-turn increments when adjusting lip assist spring. Check lip operation after each adjustment. Repeat until proper operation is obtained.

Adjust lip actuator spring tension as follows:

1. Loosen jam nut **(B)**.
2. To increase spring tension, turn nut **(B)** clockwise.
3. To decrease spring tension, turn nut **(B)** counterclockwise.
4. Tighten jam nut **(B)**.
5. Recheck operation of platform and lip. Readjust lip actuator spring tension as needed.

# ADJUSTMENTS

## Adjust Lip Stop Bolt

When at rest, lip (E) should be fully resting on the lip keepers (D) and at the lowest part of the lip keepers. If lip is not resting properly in the lip keepers, perform the following adjustment:

1. Fully raise the platform and engage the maintenance prop in the service position. Manually raise the lip and engage lip maintenance prop (not shown).
2. Loosen jam nut (B).
3. Adjust stop bolt (C) as necessary.
  - Turn stop bolt “in” (clockwise) to allow lip to fold closer to platform (A).
  - Turn stop bolt “out” (counterclockwise) to hold lip further away from platform (A).
4. Tighten jam nut (B).
5. Disengage lip maintenance prop.
6. Walk platform down to cross-traffic (stored) position.
7. Check lip position in both keepers. Repeat procedure if necessary.

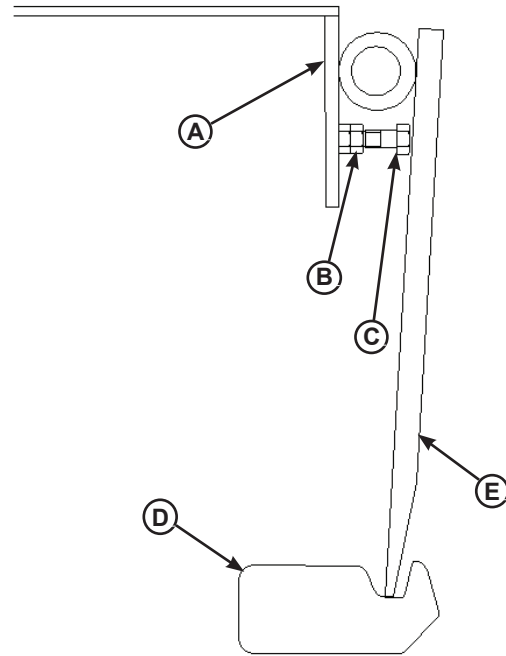

**Figure 29**

A— Platform  
B— Jam Nut  
C— Stop Bolt  
D — Lip Keeper  
E — Lip

## Adjust Lip Assist Chain and Shackle

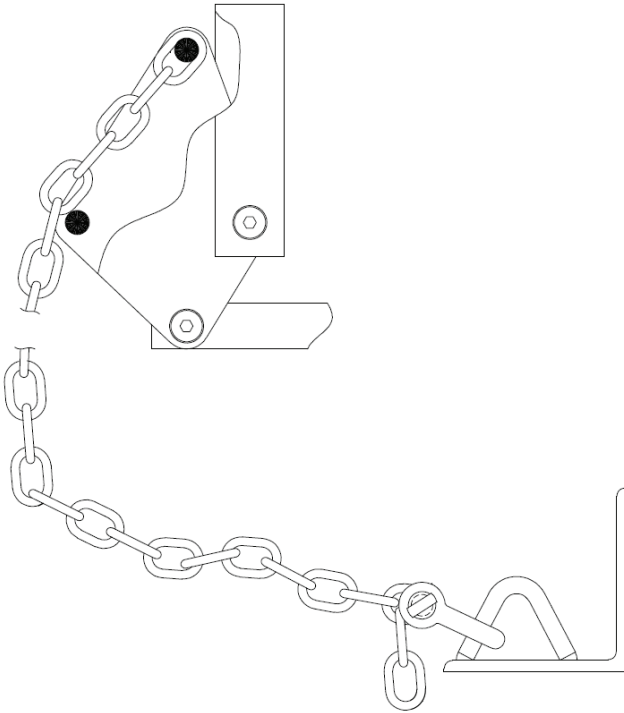

Figure 30

**The lip assist chain and shackle are set at the factory and should not require additional adjustment unless parts have been replaced.**

The above dock service range of the leveler is determined by the overall length of the lip assist chain and shackle assembly.

Above dock service range is adjusted by changing the link quantity between the lip assist assembly and the shackle. The final number of links may vary depending on application:

- **6' levelers: 31-33 links**
- **8' levelers: 32-34 links**
- **10' levelers: 33-35 links**

If the maintenance prop cannot be raised to the backside of the platform header with the dock leveler in the raised position, the dock leveler must be supported by external means and the number of links from the lip assist assembly to the shackle must be increased.

If the maintenance prop can rotate out past the platform header with the dock leveler in the raised position, the number of links from the lip assist assembly to the shackle must be decreased.

# TROUBLESHOOTING

## DANGER

Unless the dock leveler is equipped with a tethered remote, two people are required to engage the maintenance prop: one person to operate the unit, the other person to engage the maintenance prop.

In addition, it is recommended and good safety practice to use an additional means to support the dock platform and lip anytime when physically working in front of or under the dock leveler. This additional means may include, but is not limited to a boom truck, fork truck, stabilizing bar or equivalent.

## WARNING

When service under the dock leveler is required, always lock all electrical disconnects in the OFF position after raising the platform and engaging the maintenance prop.

Always post safety warnings and barricade the work area at dock level and ground level to prevent unauthorized use of the dock leveler before maintenance is complete.

A hard hat or other applicable head protection should always be worn when working under or around a dock leveler.

Always stand clear of platform lip when working in front of the dock leveler.

**Before performing the detailed troubleshooting procedures, check the following items first:**

- Check all fuses inside the control panel(s). Replace any blown fuse(s) with a fuse of equal specification.
- Make sure the correct voltages are present at the proper locations inside the control panel(s).

Symptom	Possible Cause	Solution
<b>Platform does not rise. Motor does not energize.</b>	Motor fuse blown.	Reset circuit panel or disconnect fuse. Determine cause of overload.
	Motor failure	Check voltage to motor. <ul style="list-style-type: none"> <li>• If voltage is present and motor does not energize, replace motor.</li> <li>• If voltage is not present, check all components in series with the motor.</li> </ul>
<b>Platform does not rise. Motor hums, but does not run.</b>	Incorrect voltage is present on line.	Check line for proper voltage <ul style="list-style-type: none"> <li>• If proper voltage is not present, check all components in series with the motor.</li> <li>• If proper voltage is present and motor does not run, check for obstructions.</li> <li>• If no obstructions are found, replace motor.</li> </ul>

# TROUBLESHOOTING

Symptom	Possible Cause	Solution
<b>Platform does not rise. Motor energizes, but does not run.</b>	Line voltage too low.	<ul style="list-style-type: none"> <li>• Check wiring to motor for high resistance.</li> <li>• Check for loose or corroded connections.</li> <li>• Check if gauge of wires to motor are of correct size and specification for load requirement. Replace if necessary.</li> </ul>
<b>Platform rises slowly</b>	Air bladder or connecting ducts punctured	Check air bladder and ducting for damage replace as needed
	Damaged or restricted ducting	Replace damaged ducting or remove restriction
	Air intake clogged	Remove intake filter, clean or replace as needed
	Dock leveler binding	Check for visible obstructions that could cause binding. Remove obstructions. If no obstructions found, call Technical Services. See inside back cover for phone number and address.
<b>Platform does not rise to full height.</b>	See Platform Rises Slowly	See Platform Rises Slowly See Periodic Maintenance in the Maintenance section.
<b>Platform DOES rise to full height, but lip DOES NOT extend or extend fully.</b>	Lip actuator spring needs additional tension.	Inspect lip actuator chain, repair or replace as needed.
<b>Lip extends but does not remain extended as leveler drops.</b>	Lip latch spring needs additional tension.	See Adjustment Section: Lip Latch Spring. <ul style="list-style-type: none"> <li>• Increase tension as needed to keep latch engaged.</li> <li>• Clean any debris from lip latch area.</li> <li>• Lubricate as instructed in maintenance section.</li> </ul>
	Air bladder damaged	<ul style="list-style-type: none"> <li>• Replace air bladder</li> </ul>

If additional troubleshooting assistance is required, contact Systems, LLC  
Technical Services with equipment serial number or customer order number (CO#).

**Technical Service at 800-643-5424 or [techservices@loadingdocksystems.com](mailto:techservices@loadingdocksystems.com)**

# PARTS

## Standard Control Box



Part Number	Description
9-R0-800-A-A	Push Button Starter Enclosure, NEMA 4X, AP/DA/MA (Includes Decals)*

\* Must specify DLM brand decals when e-mailing, calling or faxing controller orders.



## Optional Electrical Parts (Control Box)

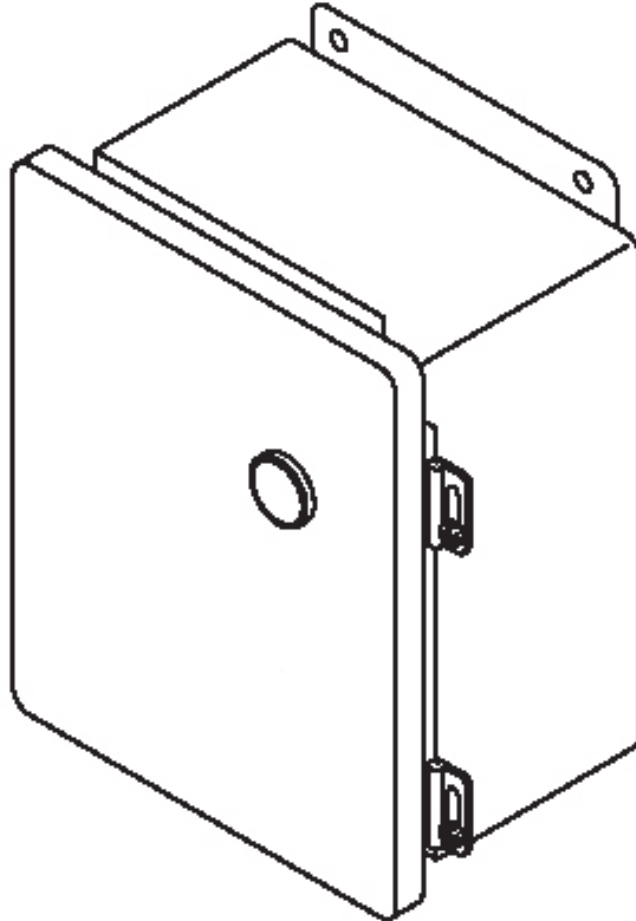

Part Number	Description
*	Control Box w/Optional Equipment

\* Provide dock leveler serial number, voltage, phase, and options when e-mailing, calling or faxing controller orders.

# PARTS

## Lip Activation (pre-2012)

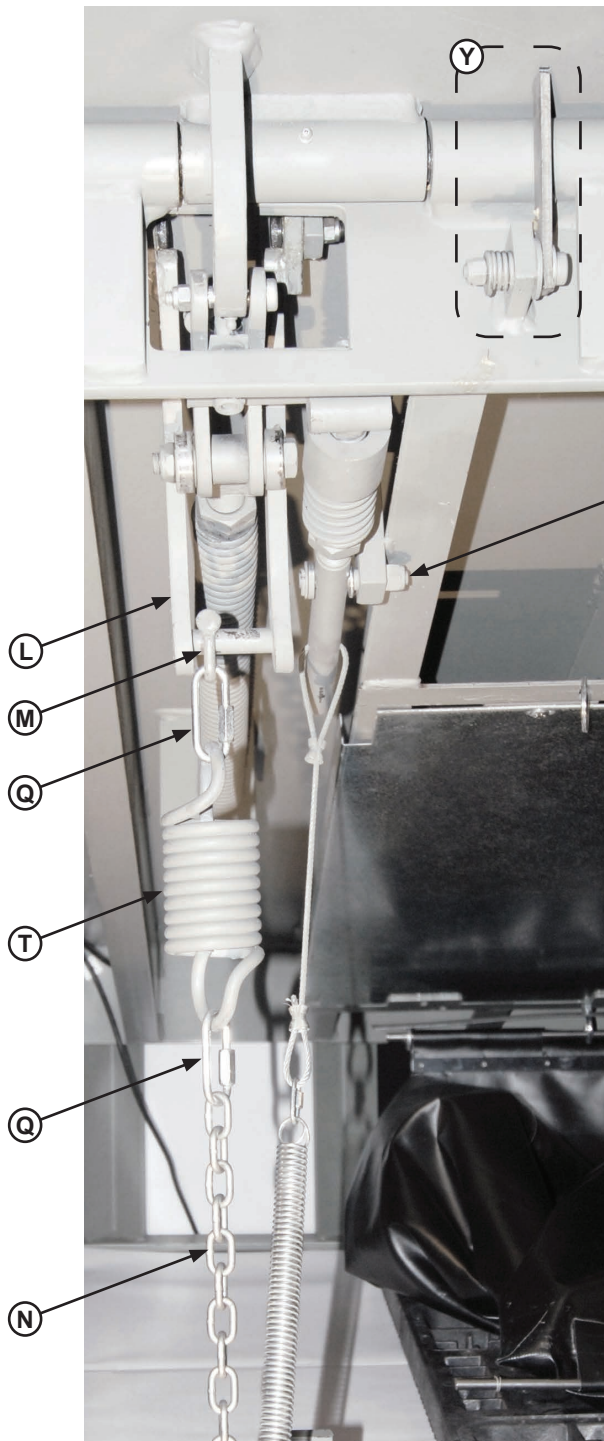

U  
V  
W  
X

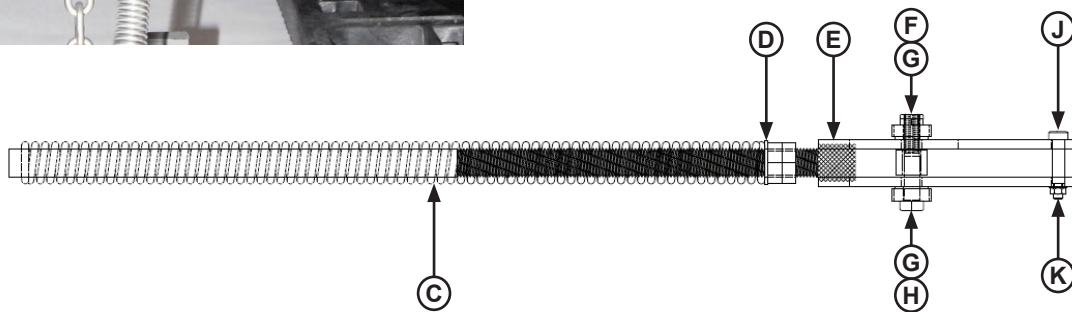
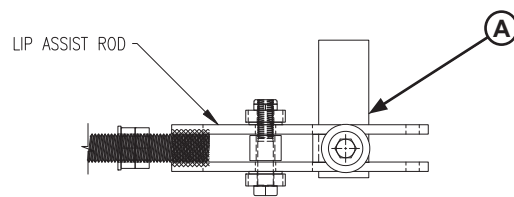
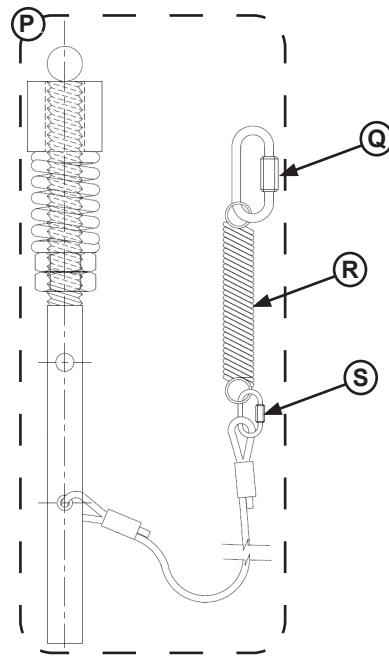

## Lip Activation (pre-2012)

Item	Quantity	Part Number	Description
A	1	9514-0107	Lip Latch Plate Assembly
C	1	DOTH-2546*	Spring, Lip Assist, Green, 30" Lg. Heavy Duty
		DOTH-2550*	Spring, Lip Assist, Orange, 30" Lg. Light Duty
D	2	2101-0221	Washer, 1-3/4"
E	1	DPLA-2130	Lip Assist Rod, 34" (Includes F-H)
F	1	DOTH-2076	Bolt, 5/8-11 UNC x 3-1/2"
G	2	DOTH-2449	Bearing
H	1	DOTH-2160	Nut, Hex, 5/8-11
J	1	DOTH-2062	Bolt, Hex, 1/2" x 2-1/2"
K	1	DOTH-2131	Locknut, Nylon Insert, 3/8-16
L	1	DPLA-2126	Lip Assist Linkage Assembly (Includes * Hardware and M-N)
*	2	DOTH-2061	Bolt, Shoulder, 1/2" x 1-1/2" (Lip Assist Fork to Platform)
	2	DOTH-2137	Locknut, Jam, Nylon, 3/8-16 (Lip Assist Fork to Platform)
M	1	DOTH-2421	Cold Shut, 5/16"
N	1	DPLA-2128	Chain, Lip Assist Link
P	1	5775-0004	Lip Latch Assembly, 16", Pre-4/2014
Q	3	2101-0217	Quick Link, 1/4"
R	1	0941-0013	Lip Latch Rod Spring
S	1	2101-0216	Quick Link, 1/8"
T	1	DOTH-2555	Spring, Snubber
U	1	DOTH-2351	Bolt, Clevis, 1/2-13 x 3-5/32
V	1	DOTH-2163	Locknut, Nylon Insert, 1/2-13
W	2	DOTH-2210	Washer, 1/2"
X	1	DOTH-2374	Cotter Pin, 1/8 x 1
Y	1	9513-0091	Assembly, Lip Prop

\* Provide dock leveler serial number, platform size, and lip size when e-mailing, calling or faxing orders.

# PARTS

## Lip Activation (2012-present)

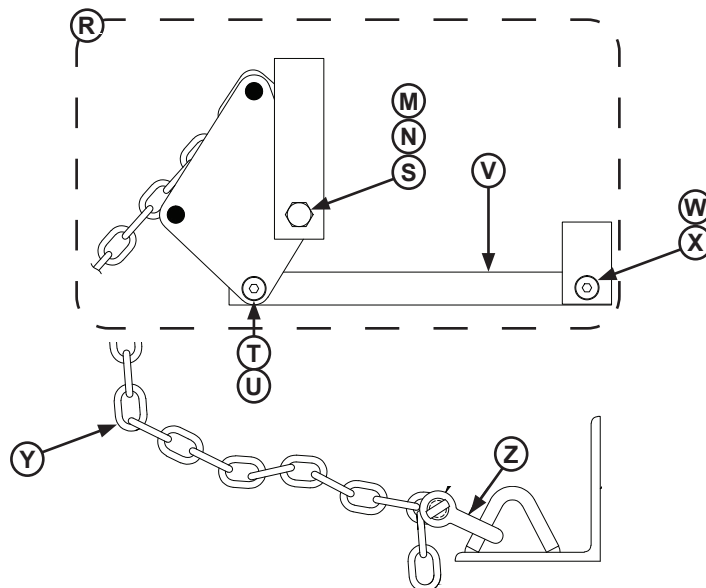
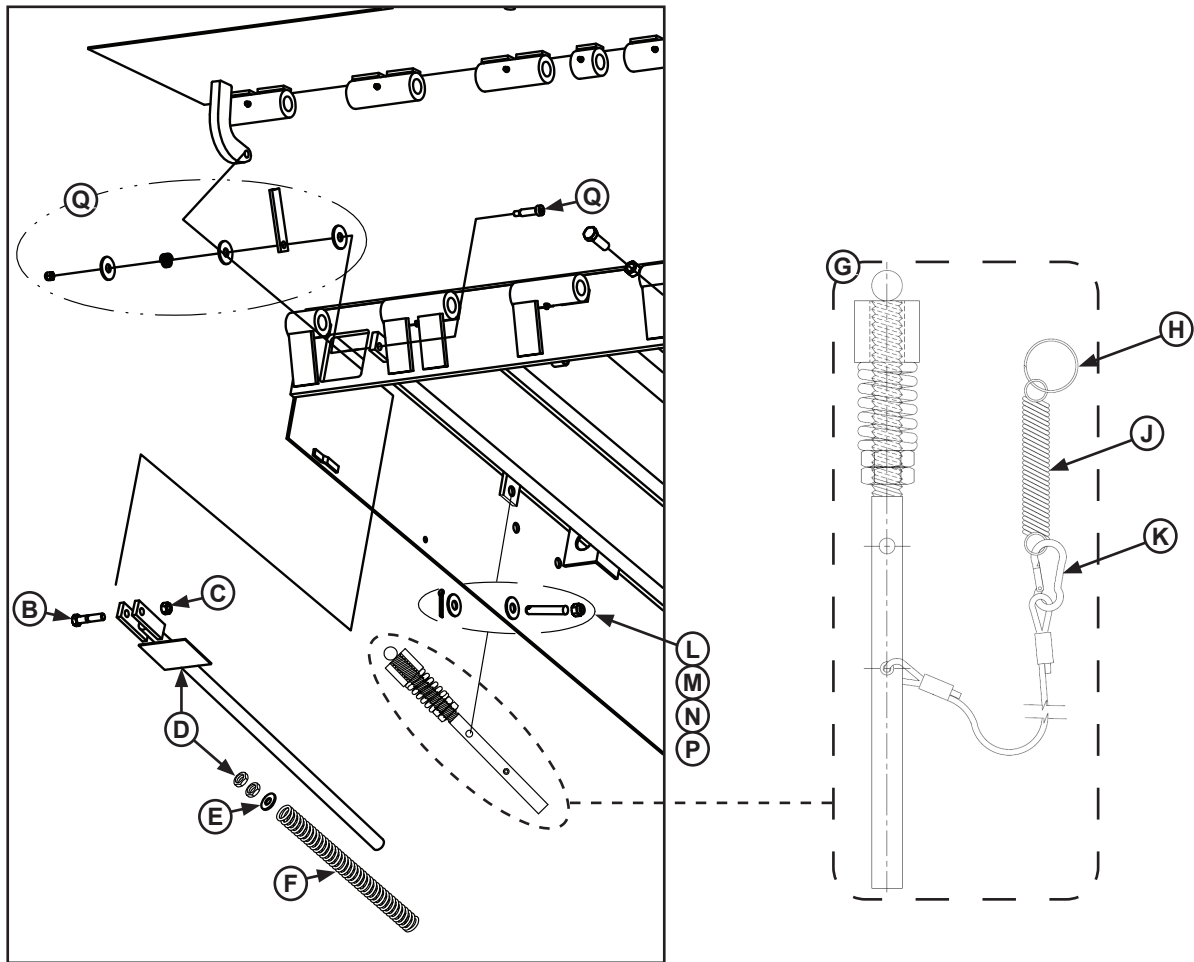

## Lip Activation (2012-present)

Item	Quantity	Part Number	Description
B	1	2101-0222	Screw, Shoulder, 1/2" x 1.75"
C	1	2101-0223	Nut, Flange Top, 3/8-16 UNC
D	1	9513-0138	Lip Assist Fork Rod (Includes E)
E	1	2101-0221	Washer, 1-3/4"
F	1	DOTH-2546*	Spring, Lip Assist, Green, 30" Lg. Heavy Duty
		DOTH-2550*	Spring, Lip Assist, Orange, 30" Lg. Light Duty
G	1	5775-0004	Lip Latch Assembly, 16", Pre-4/2014
		5775-0005	Lip Latch Assembly, 21", 4/2014-Present
H	1	2101-0230	Split Ring, 1-3/4 OD
J	1	0941-0013	Lip Latch Rod Spring
K	1	2101-0239	Chain Snap, 1/4"
L	1	DOTH-2351	Bolt, Clevis, 1/2-13 x 3-5/32
M	2	DOTH-2163	Locknut, Nylon Insert, 1/2-13
N	6	DOTH-2210	Washer, 1/2"
P	1	DOTH-2374	Cotter Pin, 1/8 x 1
Q	1	9513-0091	Assembly, Lip Prop
R	1	DPLA-0338	Lip Banger Assembly (Includes M, N, S-X)
S	1	DOTH-2065	Bolt, Hex 1/2-13 X 3-3/4 LG
T	1	DOTH-2061	Bolt, Shoulder, 1/2 x 1-1/2, 3/8-16
U	1	DOTH-2137	Lock Nut, Nylon, 3/8-16
V	1	DPLA-0341	Linkage Bar
W	1	2101-0308	Screw, Shoulder, 1/2 x 1.75 - 3/8-16 UNC BLK Oxide
X	1	DOTH-2131	Lock Nut, Nylon, 3/8-16
Y	1	2102-0002	Chain, 1/4", Grade 40/43, 35 links, 42"
Z	1	2101-0334	Shackle, 3/8"

\* Provide dock leveler serial number, platform size, and lip size when e-mailing, calling or faxing orders.

# PARTS

## Airbag and Support Pallet

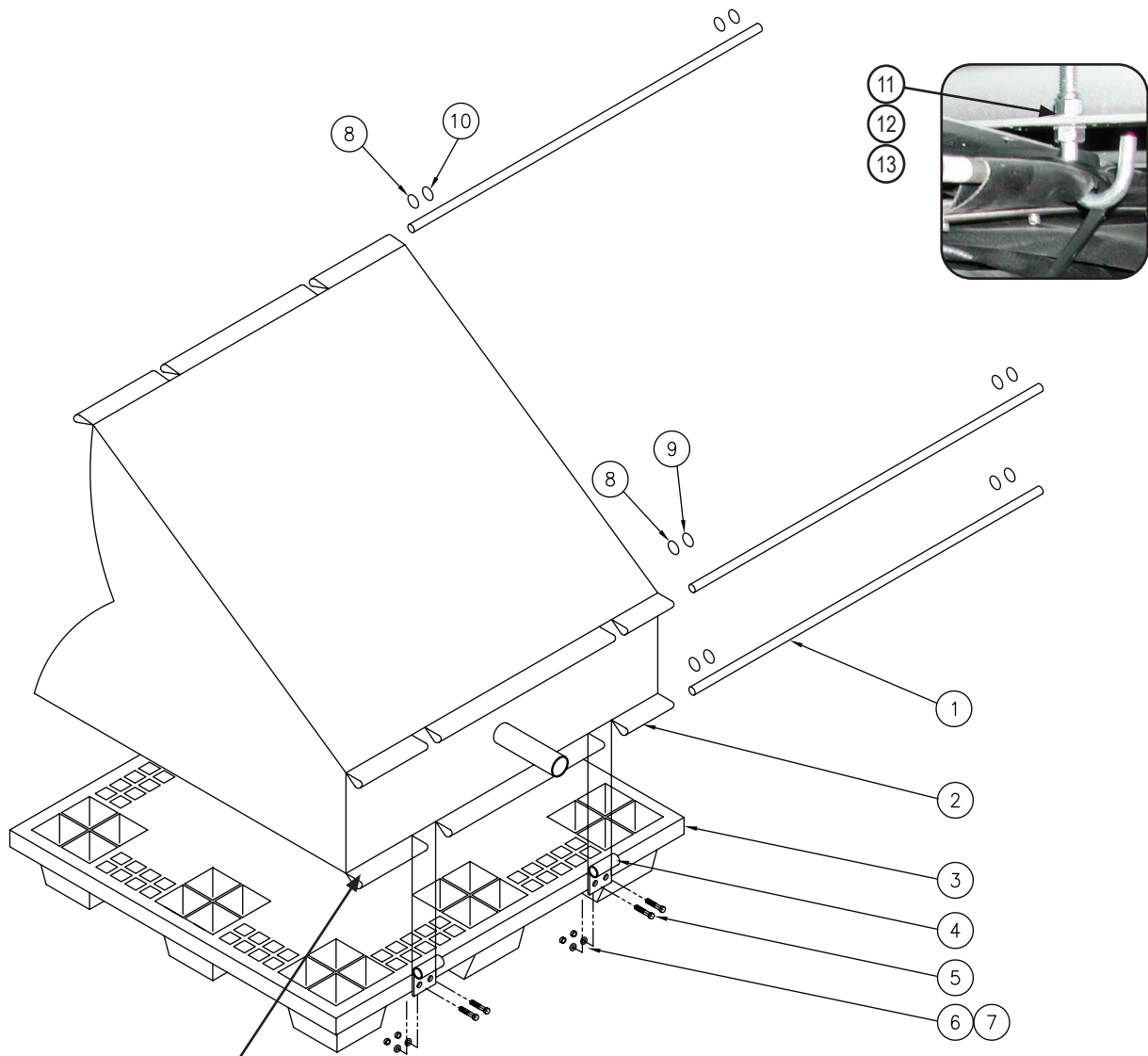

Each air bag serial number is located on the rear left hand corner near the blower assembly. If a replacement air bag is required for your dock leveler, please provide the original air bag serial number with your order.

## Airbag and Support Pallet

Item	Quantity	Part Number	Description
1	3	5812-0045	Hold Down Rod, 45" x 7/16"
2	1	5811-0009	Air Bag Bladder
*	1	5814-0029	Skid Assembly, Air Bag Leveler (Includes 3-10)
3	1	5811-0012	Skid, Air Bag Leveler
4	2	5813-0001	Skid Bracket, Air Bag Leveler
5	4	2101-0098	Screw, HHCS, 5/16-18UNC x 1-1/2 long
6	4	2101-0214	Nut, Flange Top L/N, 5/16-18
7	4	2101-0058	Washer, Lock 5/16
8	6	2101-0224	Rod Clamp, 7/16
9	4	2101-0079	Washer, 1/2"
10	2	2101-0230	Split Ring, 1-3/4 OD
11	2	2101-0231	Bolt, Hook, J, 3/8-16, 1" Eye x 4"
12	4	2101-0207	Nut, Hex, 3/8-16 UNC, Zinc Plated
13	4	2101-0060	Washer, Flat, 3/8" SAE, Zinc Plated

# PARTS

## Blower Motor Assembly

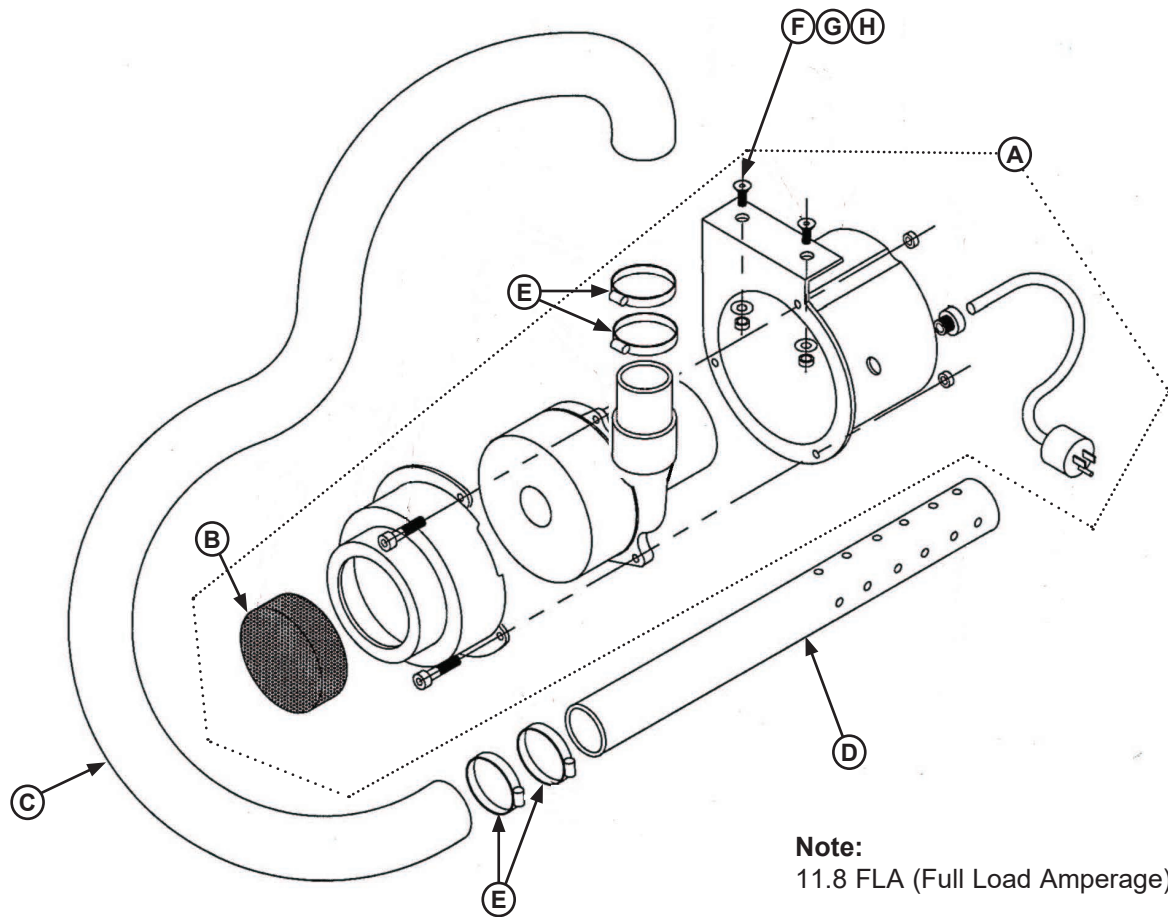



Item	Quantity	Part Number	Description
A	1	9395-0359	PPAC, Blower Assembly (Includes Filter)*
B	1	9391-0021	Filter Element
C	1	9391-0022	Hose, 2" OD, 36" Long (6' and 8' Levelers)
		9391-0041	Hose, 2" OD, 46" Long (10' levelers)
D	1	9392-0047	Blower Tube, AP, 24" Straight (8' and 10' Levelers)
		9393-0068	Blower Tube, AP, 24", 90 Degree (6' Levelers)
E	4	9391-0023	Hose Clamp, 2"
F	2	2101-0143	Nut, Nylon Lock, 1/4-20 UNC
G	2	2101-0007	Screw, HHCS, 1/4-20 UNC x 1.00, Grade 5
H	4	2101-0005	Washer, Lock, 1/4"

\* Blower assembly (A) is factory sealed. Internal blower component parts are not available for resale.

# PARTS

## Frame and Platform

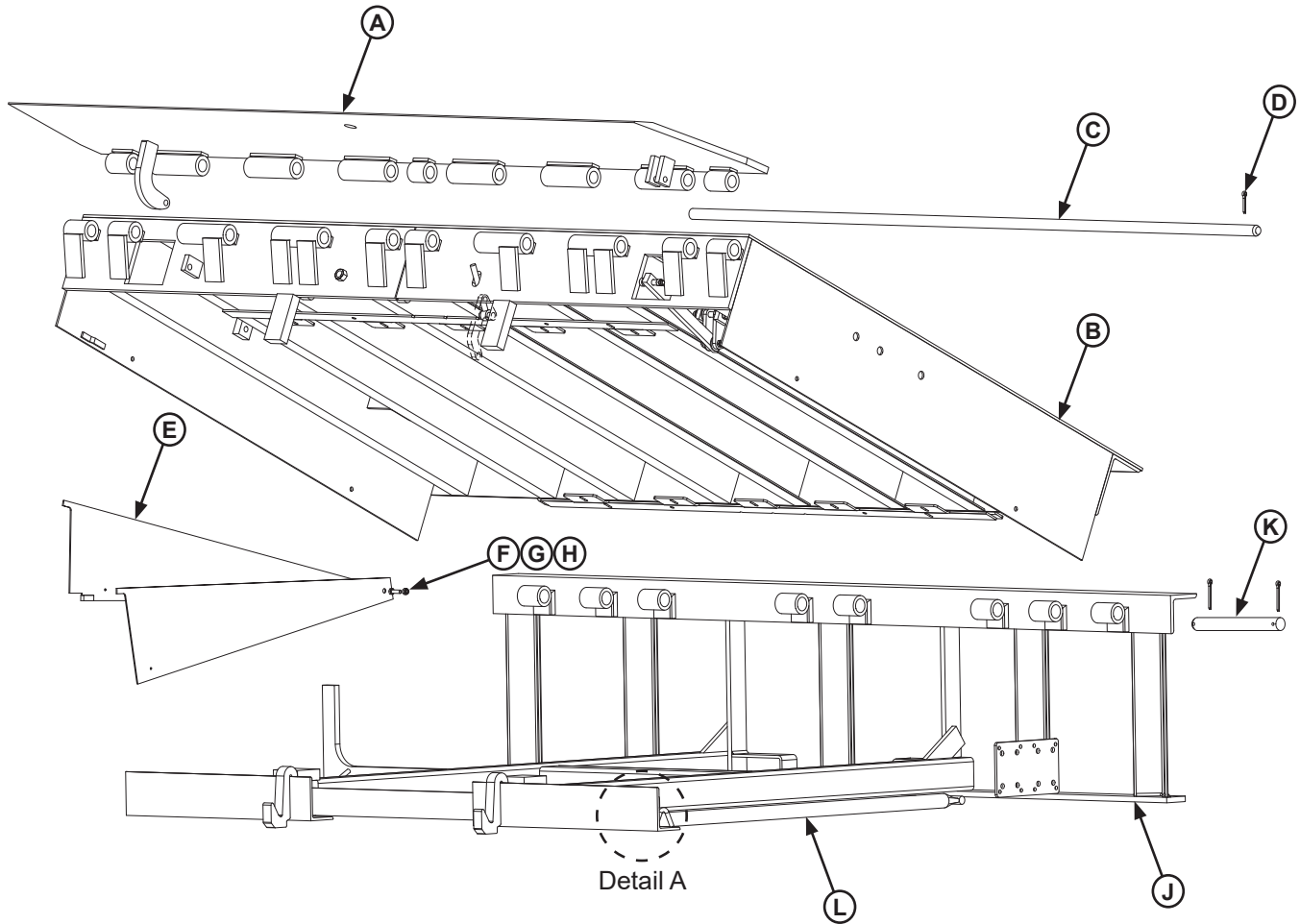

Detail A

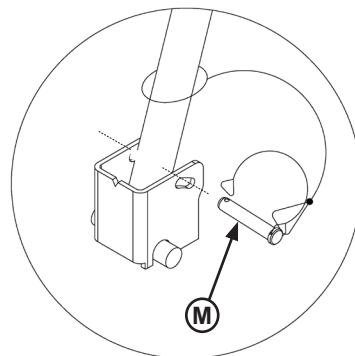

Detail A

---

**Frame and Platform**

Item	Quantity	Part Number	Description
A	1	0595-____*	Lip, Welded Assembly
B	1	9515-____*	Platform, Welded Assembly
C	2	DPLA-2101*	Pin, Lip Hinge, 1" OD x 35.25
		DPLA-2102*	Pin, Lip Hinge, 1" OD x 38.25
		DPLA-2103*	Pin, Lip Hinge, 1" OD x 40.5
D	2	DOTH-2382	Cotter Pin, 1/4 x 2
E	1	DKIT-9179	Toe Guard Kit, Sliding 6' (Includes Both Sides)
		DKIT-9180	Toe Guard Kit, Sliding 8' (Includes Both Sides)
		DKIT-9181	Toe Guard Kit, Sliding 10' (Includes Both Sides)
F	2	DOTH-2043	Bolt, Hex, 3/8-16 x 1-1/4
G	4	DOTH-2207	Washer, 7/8
H	2	DOTH-2131	Locknut, Nylon Insert 3/8-16
J	1	8435-____*	Frame, Welded Assembly
K	3	9202-0002	Pin, Hinge, Rear
		9202-0009	Pin, Hinge, Rear, Stainless Steel (Optional)
L	1	9225-____*	Maintenance Prop
M	1	9201-0006	Prop Pin & Clip

\* Provide dock leveler serial number, platform size, and lip size when e-mailing, calling or faxing orders.

# PARTS

## Below Dock Control (pre-8/2019)

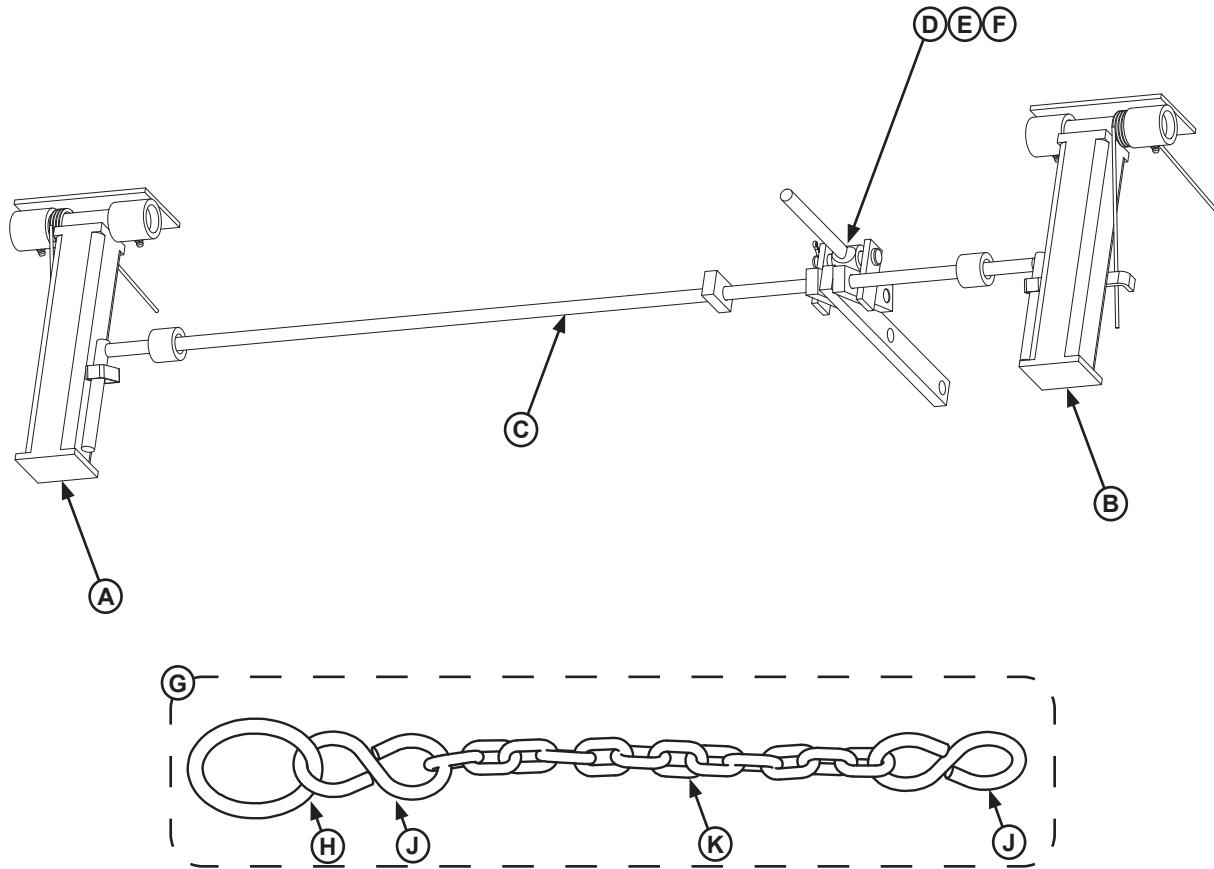

Item	Quantity	Part Number	Description
A	1	DOTH-6232	Safety Leg Weldment, RH, CA
B	1	DOTH-6321	Safety Leg Weldment, LH, CA
C	1	DPLA-2122	Safety Leg Pull Bar Assembly
D	1	DPLA-0360	Push Rod, AP, 5-1/2"
E	1	DOTH-2060	Pin, Clevis, 1/2 x 2.50
F	1	DOTH-2131	Cotter Pin, 1/8 x 1
G	1	DPLA-1215	Pull Chain Assembly (Includes K-N)
H	1	DOTH-2423	Pull Ring, Zinc Finish
J	1	DOTH-2440	Quick Link, 3/16"
K	1	DOTH-2412	Chain, 10"

## Below Dock Control (8/2019-present)

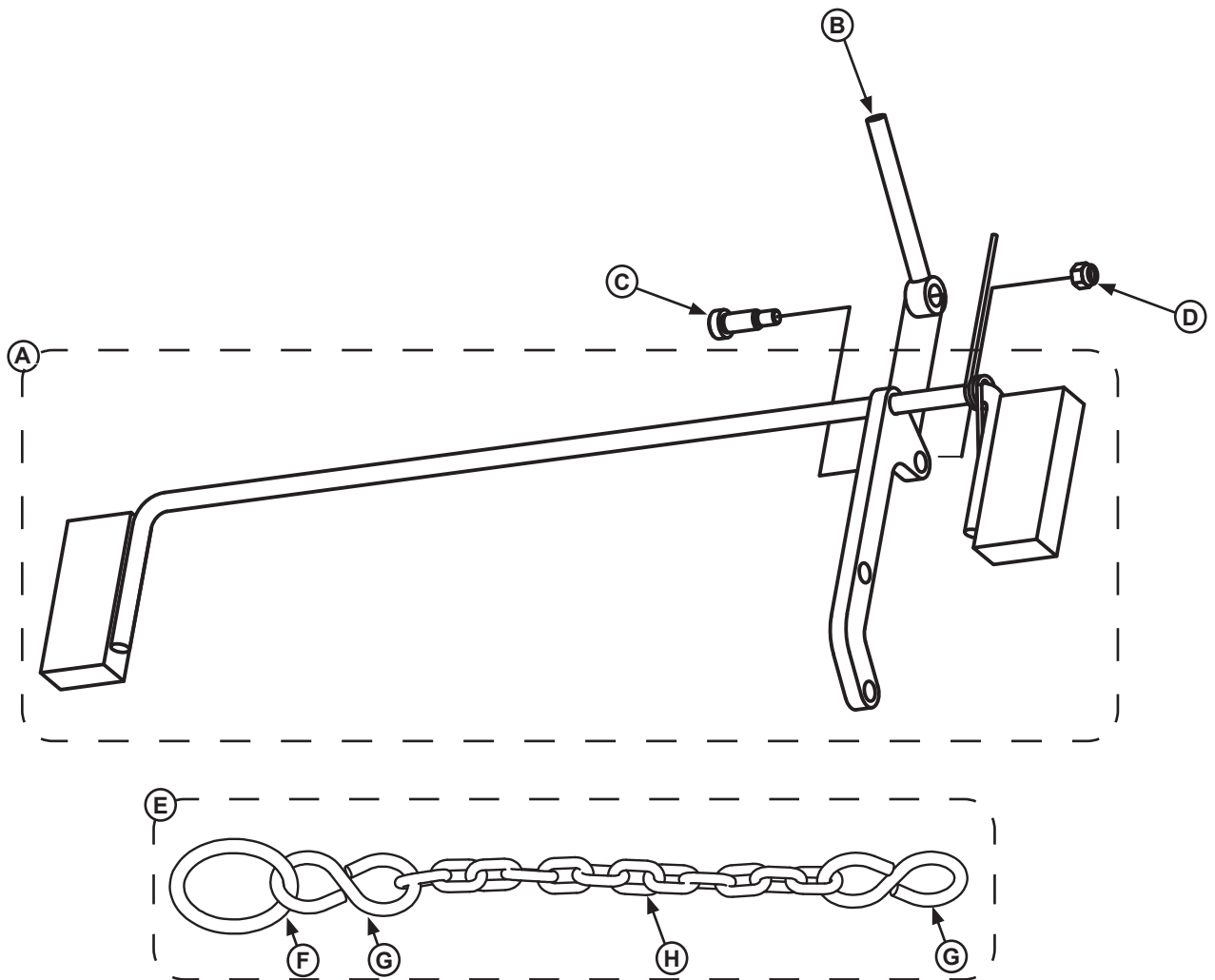

Item	Quantity	Part Number	Description
A	1	DPLA-0343	Below Dock Control Assembly
		DPLA-0401	Below Dock Control Assembly (6' Long Units Only)
B	1	DPLA-0360	Below Dock Control Push Rod Assembly
C	1	DOTH-2060	Bolt, Shoulder, 1/2 x 1, 3/8"-16 UNC
D	1	DOTH-2131	Lock Nut, Nylon, 3/8-16
E	1	DPLA-0353	Pull Chain Assembly (Includes K-N)
F	1	DOTH-2423	Pull Ring, Welded
G	1	DOTH-2440	S-Hook, Zinc Plated
H	16	DOTH-2412	Chain, Twist Link

# PARTS

## Weather Seals

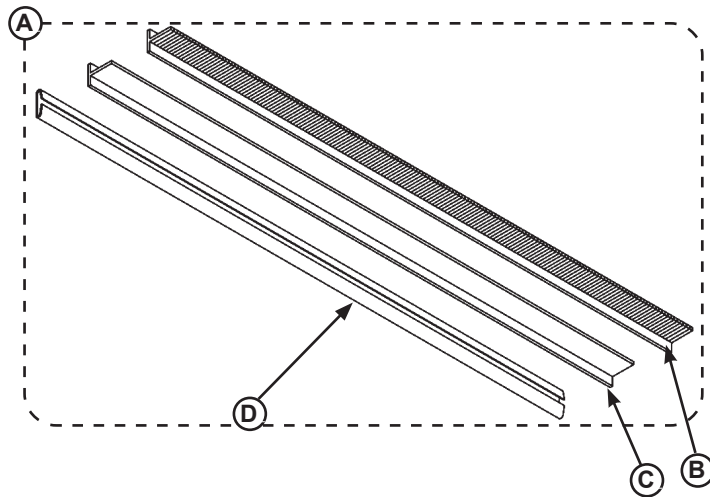

### Weather Seal Kits

Item	Quantity	Part Number	Description
A	1	DKIT-9293	Brush Kit (Includes Seal and Track), 1-1/2 in. 84" Lg. (Both Sides)
	1	DKIT-9292	Rubber Kit (Includes Seal and Track), 1-1/2 in. 84" Lg. (Both Sides)

### Individual Replacement Seals

Item	Quantity	Part Number	Description
B	1	DOTH-2822	Brush Refill, 1-1/2 in. 84" Lg.
C	1	DOTH-2824	Rubber Refill, 1-1/2 in. 84" Lg.
D	1	DOTH-2840	Replacement Channel

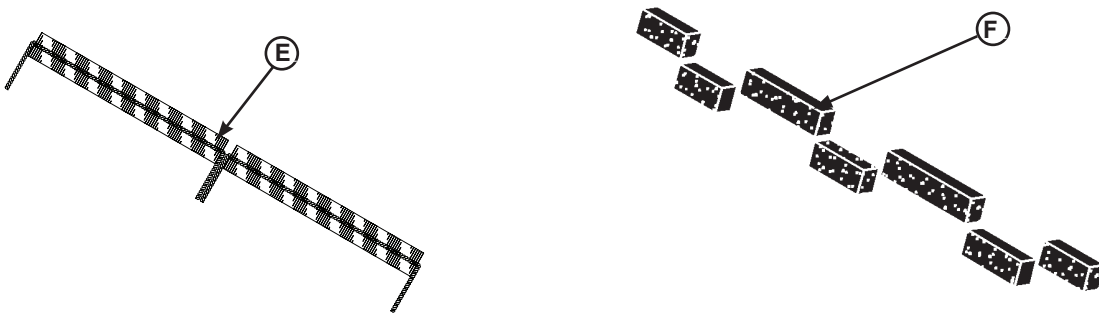

### Rear Seals

Item	Quantity	Part Number	Description
E	1	0195-0045	Rear Brush Weather Seal, Universal
F	1	0195-0046	Rear Foam Seal, Self-Adhesive, Pre-Cut, 6' Wide Levelers
		0195-0047	Rear Foam Seal, Self-Adhesive, Pre-Cut, 6.5' Wide Levelers
		0195-0048	Rear Foam Seal, Self-Adhesive, Pre-Cut, 7' Wide Levelers

\* Provide dock leveler serial number and size of platform when e-mailing, calling or faxing orders.

## Customer Information

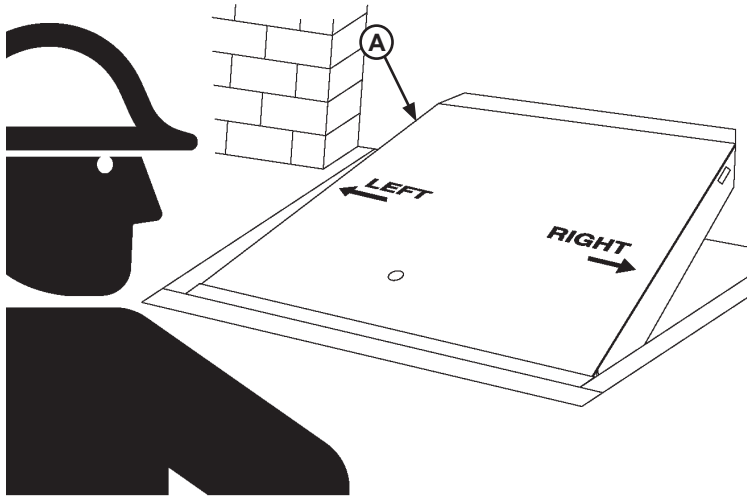

Figure 31

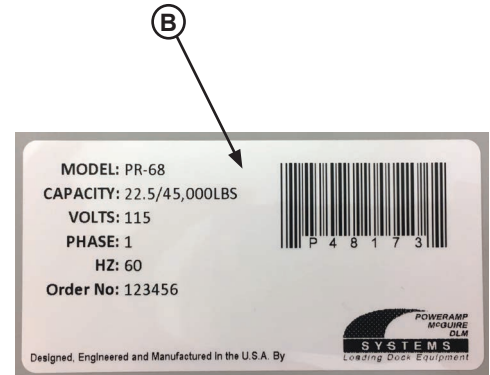

Figure 32

**NOTE:** Refer to Figure 31 for left/right orientation of dock leveler and Figure 32 for example of decal.

The LEVELER model/serial number decal is located on the left platform joist near the front (lip) of dock leveler (A).

When you receive your new equipment, write down the model and serial number in the form provided. This will help ensure safe keeping of the numbers in the event the model/serial number decal (A, B) becomes lost or damaged.

Also, write down Systems, LLC's order number, the company that installed the dock leveler, and the original owner's name. This will all help to identify the specific dock leveler if more information is required.

When ordering, use part numbers and description to help identify the item ordered. Do not use "item" numbers. These are only for locating the position of the parts. Always give dock leveler MODEL NUMBER and/or SERIAL NUMBER.

For service, call or contact:

Systems, LLC  
P.O. Box 309  
Germantown, WI 53022

Phone: (800) 643-5424  
Fax: (262) 255-5917

www.loadingdocksystems.com

### Dock Leveler Information

Model \_\_\_\_\_

Serial No. \_\_\_\_\_

Systems, LLC, Job No. \_\_\_\_\_

### Vehicle Restraint Information

Model \_\_\_\_\_

Serial No. \_\_\_\_\_

Systems, LLC Order No. \_\_\_\_\_

### Original Owner Information

Name \_\_\_\_\_

Address \_\_\_\_\_

### Installer Information

Name \_\_\_\_\_

Address \_\_\_\_\_

Date of Installation \_\_\_\_\_

## STANDARD PRODUCT WARRANTY

SYSTEMS, LLC warrants that its products will be free from defects in design, materials and workmanship for a period of one (1) year from the date of shipment. All claims for breach of this warranty must be made within 30 days after the defect is or can with reasonable care, be detected. In no event shall any claim be made more than 30 days after this warranty has expired. In order to be entitled to the benefits of this warranty, the product must have been properly installed, maintained and operated in accordance with all manufacturer's recommendations and/or specified design parameters and not otherwise have been subject to abuse, misuse, misapplication, acts of nature, overloading, unauthorized repair or modification, application in a corrosive environment or lack of maintenance. Periodic lubrication, adjustment and inspection in accordance with all manufacturers' recommendations are the sole responsibility of the Owner/User.

In the event of a defect, as determined by SYSTEMS LLC, covered by this warranty, SYSTEMS LLC shall remedy such defect by repairing or replacing any defective equipment or parts, bearing the cost for the parts, labor and transportation. This shall be exclusive remedy for all claims whether based on contract, negligence or strict liability.

## WARRANTY LIMITATIONS

THE ABOVE WARRANTIES ARE IN LIEU OF ANY OTHER WARRANTIES, WHETHER EXPRESSED OR IMPLIED, INCLUDING BUT NOT LIMITED TO ANY IMPLIED WARRANTY OF MERCHANTABILITY OR FITNESS FOR A PARTICULAR PURPOSE. SYSTEMS LLC AND ITS SUBSIDIARIES SHALL NOT IN ANY EVENT BE LIABLE TO ANYONE, INCLUDING THIRD PARTIES, FOR INCIDENTAL, CONSEQUENTIAL OR SPECIAL DAMAGES OF ANY KIND INCLUDING BUT NOT LIMITED TO, BREACH OF WARRANTY, LOSS OF USE, LOSS OF PROFIT, INTERRUPTION OF BUSINESS OR LOSS OF GOODWILL.

## PRODUCT SPECIFIC WARRANTY "DA" SERIES LEVELER

In addition to the "Standard Product Warranty" provided with all DLM® products, Systems LLC, guarantees materials, components and workmanship to be free of defects for the following extended periods:

- Structural Warranty – Structural Warranty – For an additional period of nine (9) years, product will carry a **prorated** structural warranty. This warranty specifically applies to; the deck section, lip section, frame, rear hinge assembly and front hinge assembly only. This warranty covers structural repairs to or replacement of dock leveler in Systems LLC sole discretion and expense including reasonable labor, materials, freight and travel. If Systems LLC determines replacement is necessary, it will provide the original purchaser with a credit toward the purchase of the new replacement Systems LLC product in the amount equal to the original purchase price of the warranted product F.O.B. point of manufacture, discounted on a ten year straight line basis by the number of years of use prior to replacement.
- Pneumatic Warranty – For an additional period of four (4) years, for parts and freight only, this warranty specifically applies to; the air bladder, seals, hoses and motor assembly.