

A Division of Systems, LLC

DLM
DOCK LEVELER
MANUFACTURING

DH Series

Dock Leveler

Owner's/User's Manual

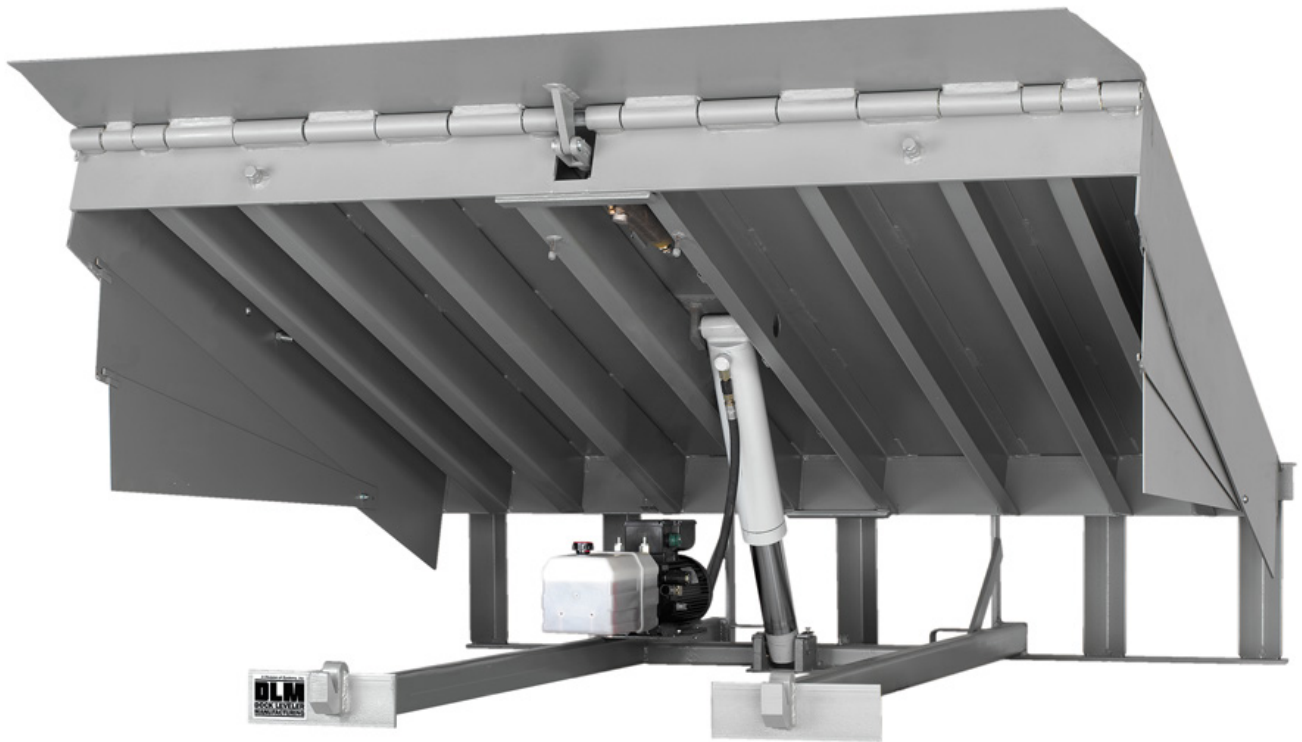

DLM • Division of Systems, LLC • W194 N11481 McCormick Drive • Germantown, WI 53022
800.643.5424 • fax: 262.255.5917 • www.dlmdocks.com • techservices@loadingdocksystems.com

Printed in U.S.A.
© 2018 Systems, LLC - All Rights Reserved

Manual No. 4111-0003
Sept. 2018

Table of Contents

	Page
Precautions	
Recognize Precautionary Information	1
General Operational Precautions	1
Operational Precautions	2
Safety Decals.....	4
Placard	5
Owner's User's Responsibilities	6
Introduction	
General Information.....	8
Component Identification.....	9
Installation	
Installation Precautions	10
Prepare Pit.....	12
Prepare Dock Leveler.....	13
Install Dock Leveler	14
Install Control Panel and Wiring	20
Placard Installation Instructions	22
Put New Dock Leveler Into Service.....	23
Operation	
Operational Precautions	24
Ramp Loading/Unloading Instructions.....	26
End Loading/Unloading Instructions	27
Optional Equipment.....	28
Maintenance	
Maintenance Precautions.....	29
Periodic Maintenance	30
Adjustments	
Valve Adjustments (Monarch/Bucher Powerpacks).....	32
Valve Adjustments (Hoke/KTI Powerpacks).....	34
Adjust Auto Return To Dock (ARTD)	36
Troubleshooting	
Troubleshooting.....	40
Parts	
Danfoss Control Box	44
Optional Electrical Parts	45
Frame and Platform	46
Hydraulic Components.....	48
Powerpack Assembly.....	50
Valve Block - Emergency Stop/Lip Out	54
Weather Seal	55
Toe Guards	56
Miscellaneous	
Customer Information	57
Warranty.....	Back Cover

PRECAUTIONS

Recognize Precautionary Information

Safety-Alert Symbol



The Safety-Alert Symbol is a graphic representation intended to convey a safety message without the use of words. When you see this symbol, be alert to the possibility of death or serious injury. Follow the instructions in the safety message panel.

DANGER

The use of the word DANGER signifies the presence of an extreme hazard or unsafe practice which will most likely result in death or severe injury.

WARNING

The use of the word WARNING signifies the presence of a serious hazard or unsafe practice which could result in death or serious injury.

CAUTION

The use of the word CAUTION signifies possible hazard or unsafe practice which could result in minor or moderate injury.

NOTICE

The use of the word NOTICE indicates information considered important, but not hazard-related, to prevent machine or property damage.

SAFETY INSTRUCTIONS

Indicates a type of safety sign, or separate panel on a safety sign, where safety-related instructions or procedures are described.

General Operational Precautions



Read and understand the Owner's/User's Manual and become thoroughly familiar with the equipment and its controls before operating the dock leveler.

Never operate a dock leveler while a safety device or guard is removed or disconnected.

Never remove DANGER, WARNING, or CAUTION signs, Placards or Decals on the equipment unless replacing them.

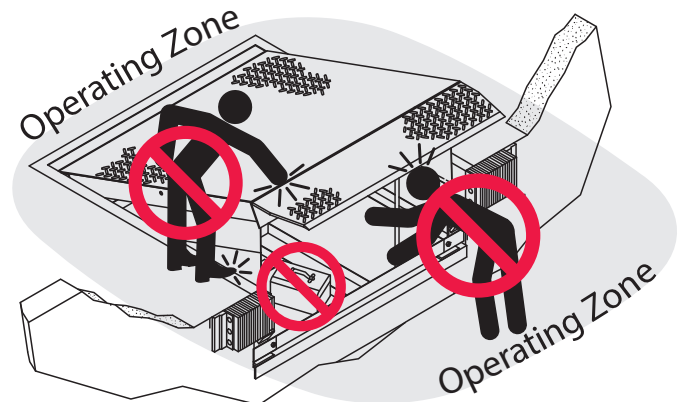

Figure 1

Do not start the equipment until all unauthorized personnel in the area have been warned and have moved outside the operating zone (see Figure 1).

Remove any tools or foreign objects from the operating zone before starting.

Keep the operating zone free of obstacles that could cause a person to trip or fall.



WARNING: This product can expose you to chemicals including lead, which are known to the State of California to cause cancer or birth defects or other reproductive harm. For more information go to www.P65Warnings.ca.gov

PRECAUTIONS

Operational Precautions



Learn the safe way to operate this equipment. Read and understand the manufacturer's instructions. If you have any questions, ask your supervisor.

DANGER



Stay clear of dock leveling device when transport vehicle is entering or leaving area.



Do not move or use the dock leveling device if anyone is under or in front of it.

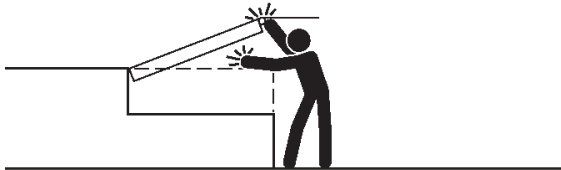

Keep hands and feet clear of pinch points. Avoid putting any part of your body near moving parts.

WARNING



Chock/restrain all transport vehicles. Never remove the wheel chocks or release the restraining device until loading or unloading is finished, and transport driver has been given permission to drive away.



Do not use a broken or damaged dock leveling device or restraining device. Make sure proper service and maintenance procedures have been performed before using.



Make sure lip overlaps onto transport vehicle bed at least 4 in. (102 mm).



Keep a safe distance from both side edges.

Operational Precautions

! WARNING

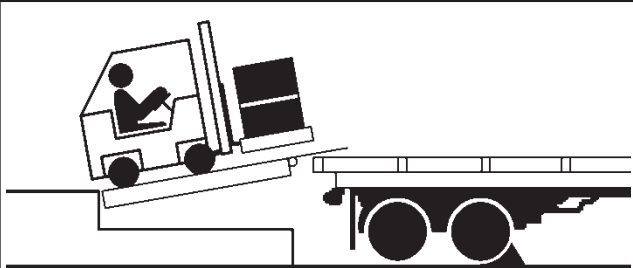

Do not use dock leveling device if transport vehicle is too high or too low.

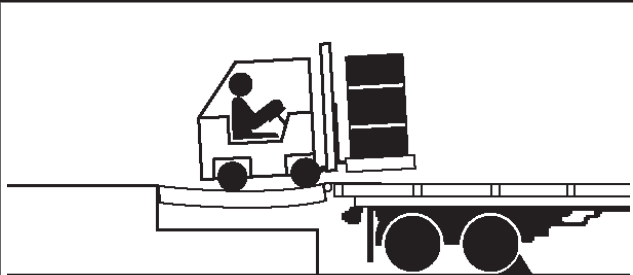

Do not overload the dock leveling device.



Do not operate any equipment while under the influence of alcohol or drugs.

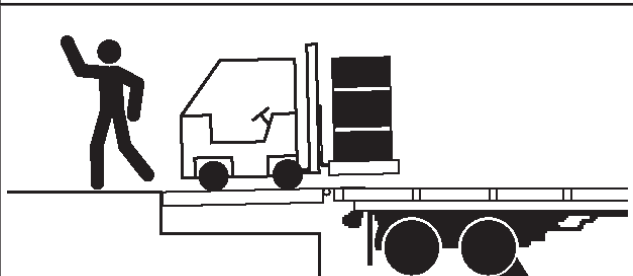

Do not leave equipment or material unattended on dock leveling device.

PRECAUTIONS

Safety Decals



1751-0329



1751-0330 Two positions one on top of each fork pocket.

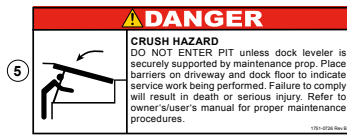

1751-0726

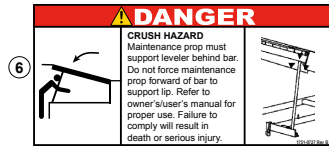

1751-0727



1751-0729



1751-0138

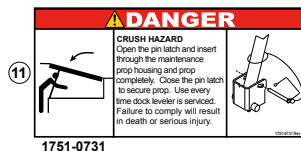

1751-0731

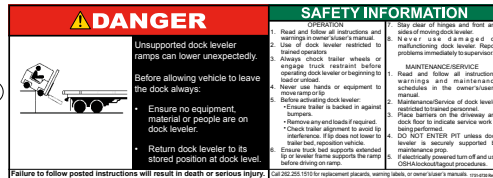

1751-0730

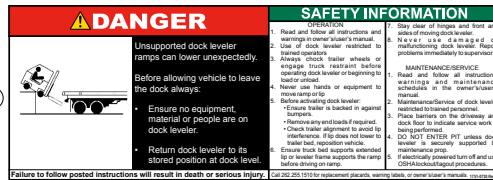

1751-0730

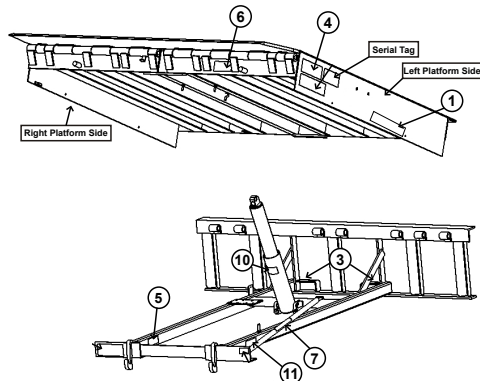



Figure 2

Placard



DANGER

OPERATING INSTRUCTIONS

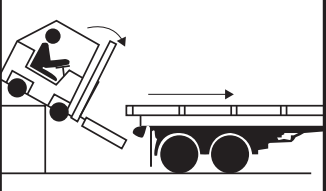

- Read and follow all instructions, warnings, and maintenance schedules in the manual and on placards.
- Operation and servicing of dock leveler is restricted to authorized personnel.

POWERED DOCK LEVELERS

NORMAL OPERATION

1. Raise the platform by Pressing and holding the RAISE button.
2. Hold the RAISE button until the lip is fully extended, then release the RAISE button. The platform will lower until lip is resting on the transport vehicle.

STORING LEVELER

1. Press the RAISE button until the lip is completely folded. When the lip is folded, release the RAISE button. The platform will lower returning to the cross-traffic position.

BELOW DOCK ENDLOADING

- (AIR POWERED ONLY)** Press and hold the RAISE button until the leveler is 12" above dock level. Pull the below dock level chain until the leveler lowers the full below dock position.
- (HYDRAULIC ONLY)** Press and hold the RAISE button until the leveler is fully raised. As the lip starts to extend, release the RAISE button. The leveler will lower to the below dock position provided the lip extension allows the lip to clear the lip keepers.
- (HYDRAULIC WITH INFINITE LIP CONTROL)** If equipped, raise the platform by Pressing and holding the RAISE button. When the lip is just above the lip keepers, simultaneously Press and hold the RAISE button and the LIP OUT button until lip has extended beyond the lip keepers. Release both buttons.

FAILURE TO FOLLOW THESE INSTRUCTIONS WILL RESULT IN DEATH OR OTHER SERIOUS INJURY.



Scan to view our owner's/user's manuals online.
www.LoadingDockSystems.com
1.800.643.5424
 Call for additional placards, or manuals, or with questions regarding proper use, maintenance, and repair of dock leveler.



1751-0874

WARNING: CANCER AND REPRODUCTIVE HARM
www.P65Warnings.ca.gov

1751-0874 Rev D

NOTE: If equipped, Pressing E-STOP button will stop platform from lowering.

OWNER'S/USER'S RESPONSIBILITIES

- 1) The manufacturer shall provide to the initial purchaser and make the following information readily available to the owners/users and their agents, all necessary information regarding Safety Information, Operation, Installation and Safety Precautions, Recommended Initial and Periodic Inspections Procedures, Planned Maintenance Schedule, Product Specifications, Troubleshooting Guide, Parts Break Down, Warranty Information, and Manufacturers Contact Information, as well as tables to identify the grade(slope) for all variations of length or configuration of the dock leveling device and information identifying the maximum uncontrolled drop encountered when sudden removal of support while in the working range of the equipment.
- 2) When selecting loading dock safety equipment, it is important to consider not only present requirements but also future plans and any possible adverse conditions, environmental factors or usage. The owners/users shall provide application information to the manufacturer to receive recommendations on appropriate equipment specifications and capacity.
- 3) The owner/user must see all nameplates, placards, decals, instructions and posted warnings are in place and legible and shall not be obscured from the view of the operator or maintenance personnel for whom such warnings are intended for. Contact manufacturer for any replacements.
- 4) Dock leveling devices may become hazardous if the manufacturer's instructions regarding modifications or adjustments are not followed. Modifications or alterations of dock leveling devices shall only be made with prior written approval from the original manufacturer. These changes shall be in conformance with all applicable provisions of the MH30.1 standard and shall also satisfy all safety recommendations of the original equipment manufacturer of the particular application.
- 5) The owner/user should recognize the inherent dangers of the interface between the loading dock and the transport vehicle. The owner/ user should, therefore, train and instruct all operators in the safe operation and use of the loading dock equipment in accordance with manufacturer's recommendations and industry standards. Effective operator training should also focus on the owner's/user's company policies, operating conditions and the manufacturer's specific instructions provided with the dock leveling device. Maintaining, updating and retraining all operators on safe working habits and operation of the equipment, regardless of previous experience, should be done on a regular basis and should include an understanding and familiarity with all functions of the equipment. Owners/users shall actively maintain, update and retrain all operators on safe working habits and operations of the equipment.
- 6) An operator training program should consist of, but not necessarily be limited to, the following:
 - a) Select the operator carefully. Consider the physical qualifications, job attitude and aptitude.
 - b) Assure that the operator reads and fully understands the complete manufacturer's owners/users manual.
 - c) Emphasize the impact of proper operation upon the operator, other personnel, material being handled, and equipment. Cite all rules and why they are formulated.
 - d) Describe the basic fundamentals of the dock leveling device and components design as related to safety, e.g., mechanical limitation, stability, functionality, etc.
 - e) Introduce the equipment. Show the control locations and demonstrate its functions. Explain how they work when used properly and maintained as well as problems when they are used improperly.
 - f) Assure that the operator understands the capacity rating, nameplate data, placards and all precautionary information appearing on the dock leveling device.
 - g) Supervise operator practice of equipment.
 - h) Develop and administer written and practical performance tests. Evaluate progress during and at completion of the course.
 - i) Administer periodic refresher courses. These may be condensed versions of the primary course and include on-the-job operator evaluation.

OWNER'S/USER'S RESPONSIBILITIES

- 7) Loading dock safety equipment should never be used outside of its vertical working range, or outside the manufacturer's rated capacity. It shall also be compatible with the loading equipment and other conditions related to dock activity. Please consult the manufacturer if you have any questions as to the use, vertical working range or capacity of the equipment. Only properly trained and authorized personnel should operate the equipment.
- 8) It is recommended that the transport vehicle is positioned as close as practical to the dock leveling device and in contact with both bumpers. When an industrial vehicle is driven on or off a transport vehicle during loading and unloading operations, the transport vehicle parking brakes shall be applied and wheel chocks or a restraining device that provides equal or better protection of wheel chocks shall be engaged. Also, whenever possible, air-ride suspension systems should have the air exhausted prior to performing said loading and unloading operations.
- 9) When goods are transferred between the loading dock and a trailer resting on its support legs/ landing gear instead of a tractor fifth wheel or converter dolly, it is recommended that an adequate stabilizing device or devices shall be utilized at the front of the trailer.
- 10) In order to be entitled to the benefits of the standard product warranty, the dock safety equipment must have been properly installed, maintained and operated in accordance with all manufacturer's recommendations and/ or specified design parameters and not otherwise have been subject to abuse, misuse, misapplication, acts of nature, overloading, unauthorized repair or modification, application in a corrosive environment or lack of maintenance. Periodic lubrication, adjustment and inspection in accordance with all manufacturers' recommendations are the sole responsibility of the owner/user.
- 11) Manufacturer's recommended maintenance and inspection of all dock leveling devices shall be performed in conformance with the following practices: A planned maintenance schedule program must be followed, only trained and authorized personnel shall be permitted to maintain, repair, adjust and inspect dock leveling devices, and only the use of original equipment manufacturer parts, manuals, maintenance instructions, labels, decals and placards or their equivalent. Written documentation of maintenance, replacement parts or damage should be kept. In the event of damage, notification to the manufacturer is required.
- 12) Loading dock devices that are structurally damaged or have experienced a sudden loss of support while under load, such as might occur when a transport vehicle is pulled out from under the dock leveling device, shall be removed from service, inspected by a manufacturer's authorized representative, and repaired or replaced as needed or recommended by the manufacturer before being placed back in service.

INTRODUCTION

General Information



Figure 3

This manual provides current information on the DH-series dock leveler. Due to ongoing product improvement, some parts may have changed, along with operation and troubleshooting methods. This manual describes these changes where applicable.

The DH-series dock leveler comes equipped with an electrical control panel, which allows push button operation of the dock leveler functions. When combining a DH-series dock leveler with a DLM hydraulic vehicle restraint, the control panel will allow for operation of both units in the same control panel.

Each DH-series dock leveler unit and control panel has been factory pre-wired and tested to ensure satisfactory operation.

To illustrate which connections are to be made in the field at installation, electrical drawings are included with each order or by contacting Systems, LLC Technical Services.

DH-series dock levelers are available in the following sizes and weight capacities:

Width

6 ft (1829 mm)
6-1/2 ft (1981 mm)
7 ft (2134 mm)

Length

6 ft (1829 mm)
8 ft (2438 mm)
10 ft (3048 mm)

Capacity (CIR*)

25,000 lb (11 340 kg)
30,000 lb (13 608 kg)
35,000 lb (15 876 kg)
40,000 lb (18 144 kg)
45,000 lb (20 412 kg)
50,000 lb (22 680 kg)
60,000 lb (27 216 kg)

* CIR (Comparative Industry Rating)

Call Systems, LLC to discuss available voltages, phases and options to meet your specific needs.

Technical Service at 800-643-5424 or techservices@loadingdocksystems.com

Component Identification

Inspect package and all components. Report any missing or damaged items immediately and note on the shipping Bill Of Lading (BOL).

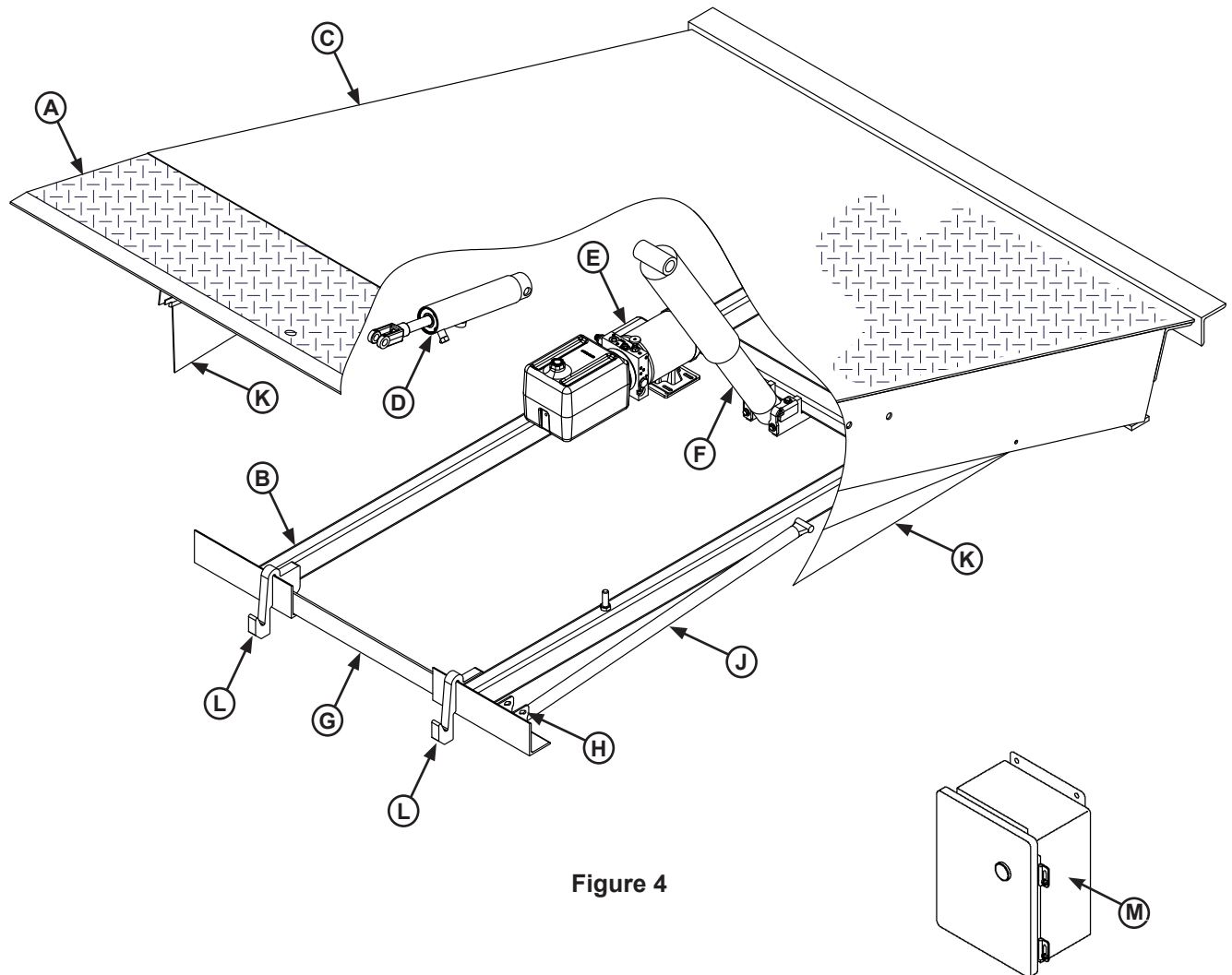

Figure 4

- | | | | |
|----------------|--------------------------------------|-----------------------------------|--------------------------|
| A — Lip | D — Lip Cylinder | G — Clean Sweep Removable Section | K — Toe Guards (2 used) |
| B — Main Frame | E — Powerpack (Motor/Pump/Reservoir) | H — Maintenance Prop Lock-Out | L — Lip Keepers (2 used) |
| C — Platform | F — Platform Cylinder | J — Maintenance Prop | M — Control Box |

* Control box appearance may vary depending on options.

INSTALLATION

Installation Precautions

DANGER

It is recommended and good safety practice to use an additional means to support the dock platform and lip anytime when physically working in front of or under the dock leveler. This additional means may include, but is not limited to a boom truck, fork truck, stabilizing bar or equivalent.

WARNING

Always post safety warnings and barricade the work area at dock level and ground level to prevent unauthorized use of the dock leveler before installation is complete.

A hard hat or other applicable head protection should always be worn when working under or around a dock leveler.

Always stand clear of platform lip when working in front of the dock leveler.

WARNING

DO NOT grind or weld if hydraulic fluid or other flammable liquid is present on the surface to be ground or welded.

DO NOT grind or weld if uncontained hydraulic fluid or other flammable liquid is present. Stray sparks can ignite spills or leaks near the work area. Always clean up the oil leaks and spills before proceeding with grinding or welding.

Always keep a fire extinguisher of the proper type nearby when grinding or welding.

CAUTION

Only trained installation professionals with the proper equipment should install this product.

NOTICE

DO NOT connect the dock leveler electrical wiring and ground connections until all welding has been completed.

DO NOT ground welding equipment to any hydraulic or electrical components of the dock leveler. Always ground welding equipment to the dock leveler frame, NEVER to the platform.

Failure to follow these instructions may damage the motor, hydraulics, wiring, and/or control panel.

NOTICE

DO NOT remove the shipping bands around the dock leveler lip until instructed to do so.

This page intentionally left blank.

INSTALLATION

Prepare Pit

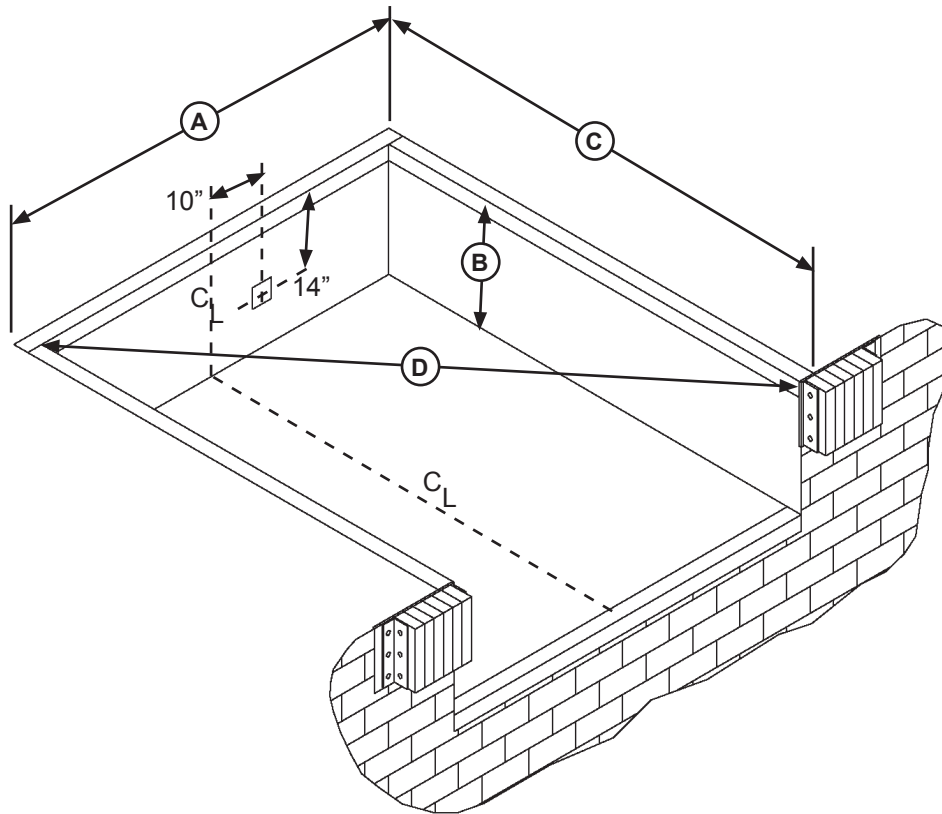

Figure 5

A—Pit Width
(Front and Rear)

B— Dock Floor-to-Pit Floor
(All Four Corners)

C— Pit Length
(Both Sides of Pit)

D— Pit Corner-to-Corner
(Top, Bottom, and Both Sides)

Before lowering the dock leveler into the pit, the following must be performed:

1. Remove all debris from the pit and sweep the pit clean.
2. Check the entire dock leveler pit for proper construction according to approved/certified pit drawings. Make sure pit is square by making the following measurements (see Figure 5):
 - Measure pit width distance (**A**) at both front and rear of pit.
 - Measure dock floor-to-pit floor distance (**B**) at all four corners.
 - Measure pit length distance (**C**) at both sides.
 - Measure corner-to-corner (diagonal) distance (**D**) at both sides. Take measurements at dock floor level and at pit floor level.

If any measurement is off by more than 1/8 in. (3.18 mm), contact Systems, LLC Technical Services before proceeding.

3. Make sure the field junction box for the dock leveler is at the correct location per pit diagrams.

Prepare Dock Leveler

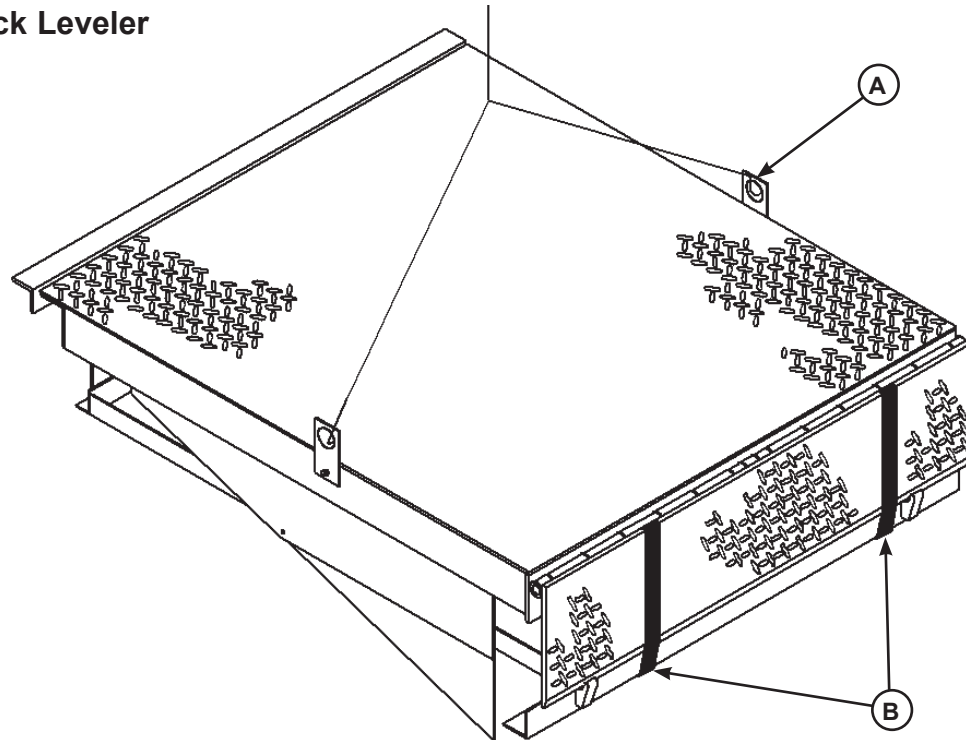

Figure 6

A— Lifting Bracket (2 used)

B — Shipping Bands

DLM dock levelers are shipped with lifting brackets (A) fastened to the platform side joists, and shipping bands (B) around the platform lip and leveler frame (see Figure 6).

1. Remove any bumpers and/or control panels that may be banded to the frame of the dock leveler.

3. Attach lifting chains to lifting brackets (A) and to a lifting device (i.e., hoist or fork truck) having the appropriate lifting capacity and reach.

4. Remove wood blocks that are attached to the leveler frame before putting the dock leveler into the pit.

5. Proceed to “Install Dock Leveler” on Page 14.

NOTICE

DO NOT remove the shipping bands (B) around the platform lip and leveler frame at this time. The shipping bands are needed to hold the leveler together during the installation process.

Note: Overall width of platform and lifting brackets (A) must be kept to a minimum to prevent interference between the lifting brackets and the pit walls as the dock leveler is lowered into the pit.

2. Make sure the mounting hardware of lifting brackets (A) is snug. The brackets should pivot without binding on the mounting cap screw.

NOTICE

DO NOT over-tighten the lifting bracket hardware. Over-tightening can damage the weather seal, if equipped.

INSTALLATION

Install Dock Leveler

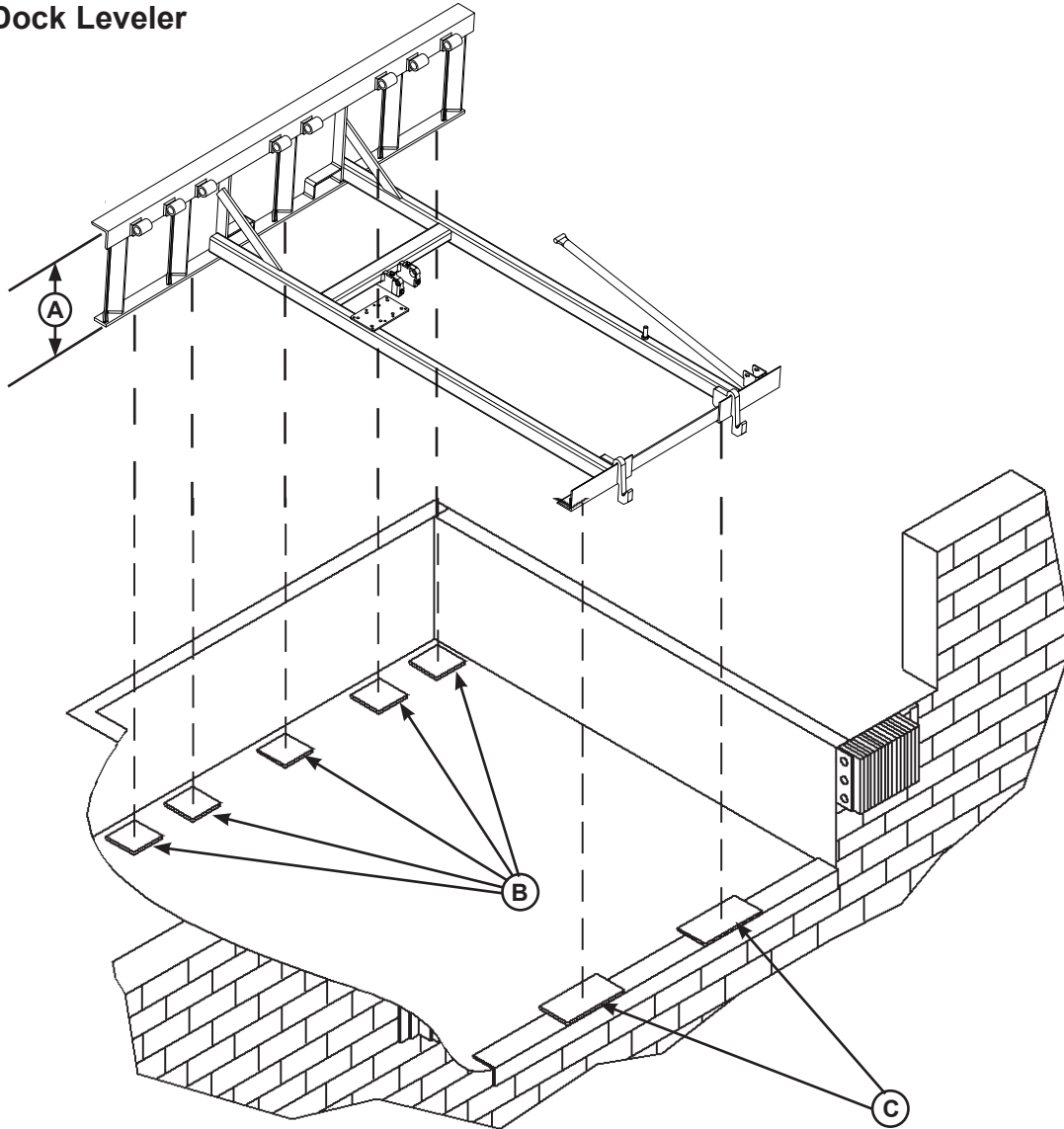

Figure 7

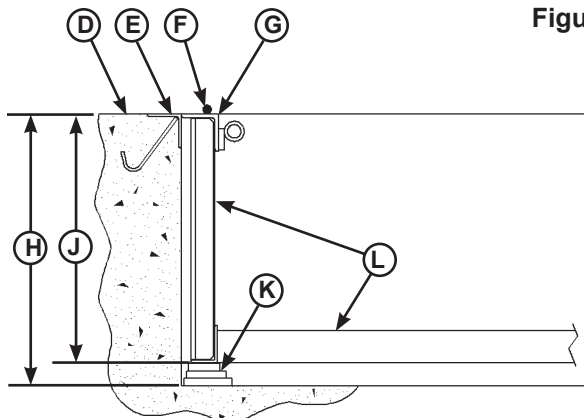

Figure 8

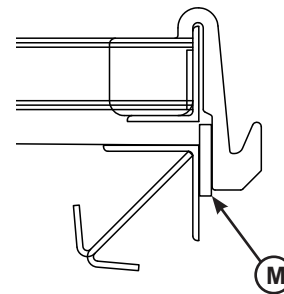

Figure 9

A— Distance (Leveler Frame Height)
 B— Shim Locations (Under Rear Vertical Supports)
 C— Shim Locations (Under Lip Keepers)

D— Dock Floor
 E— Rear Pit Curb Angle
 F— String
 G— Rear Hinge Frame Angle

H— Distance (Dock Floor-to-Pit Floor)
 J— Distance (Top of Shim Stack-to-Dock Floor)

K— Shim Stack
 L— Dock Leveler Frame
 M— Lip Keeper Shim (Between lip keeper and curb angle, as required)

Install Dock Leveler (continued)

Note: DLM dock levelers are designed with a nominal 1/2" (12.7 mm) shimming distance to allow for pit inconsistencies.

1. Determine height of shim stack (**K**) for each shim location (**B**) by performing the following:

- a. Measure leveler frame height distance (**A**).
- b. Measure dock floor-to-pit floor distance (**H**) at each shim location (**B**). Write down the dimensions obtained at each location.
- c. Subtract distance (**A**) from distance (**H**) to obtain the shim height. Repeat for each shim location.

2. Using the results obtained in step 1, create the individual shim stacks on the pit floor at location (**B**). Build each shim stack (**M**) with the top shim having a minimum size of 4-1/2" x 4-1/2" (114.3 mm x 114.3 mm) and each successive lower shim being larger so the shims can be welded together using a fillet weld. If using offset method, make sure load is over center of shim stack, NOT over the edge. DO NOT use straight method. See Figure 10.

NOTICE

The minimum size of the shim that contacts the leveler frame (i.e. the top shim of each shim stack) must be at least 4-1/2" x 4-1/2" (114.3 mm x 114.3 mm) to support the full width of the frame rail and to provide a shelf for a fillet weld.

Use the thickest shim stock possible for stability and weld penetration purposes. DO NOT use multiple layers of 1/8 in. (3.18 mm) or thinner shim stock.

Note: To assist in obtaining an accurate measurement of distance (**J**), use a string (**F**) pulled tight across the pit opening, directly over the shim locations.

3. Verify that each shim stack is at the correct height by measuring distance (**J**) [top of shim stack (**K**) to dock floor]. Distance (**J**) must equal the dock leveler height (**A**).

4. Put a 1/4" (6.6 mm) thick shim underneath each lip keeper (**C**).

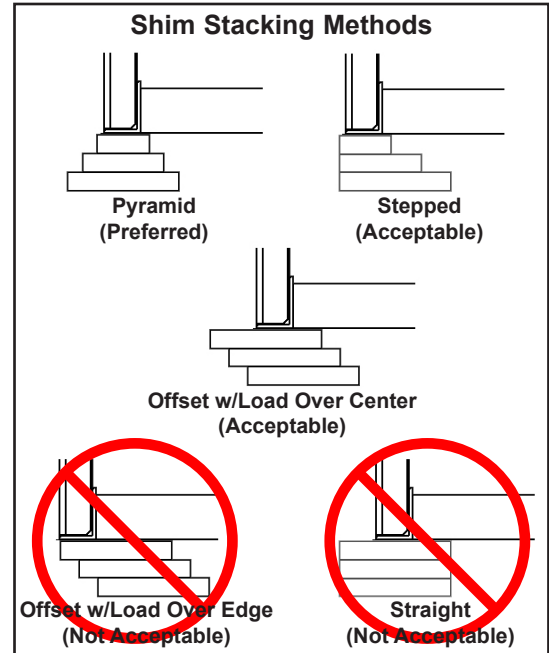

Figure 10

Note: A 1/4" (6.6 mm) thick shim at location (**C**) is used only as a starting point. The final shim stack height will be determined after dock leveler is lowered into the pit.

5. Using an appropriate lifting device connected to the lifting brackets, lower dock leveler into the pit so rear hinge frame angle (**G**) is tight against rear pit curb angle (**E**) across full width of the leveler frame.

WARNING

The dock leveler is heavy. Use a lifting device and chains with the appropriate lifting capacity and reach.

Always use the lifting brackets provided with the unit whenever lowering or lifting a dock leveler into or out of a pit.

6. Allow rear of dock leveler to rest on the rear shims while keeping the front of the dock leveler level with the dock floor.

7. Add shims at front shim locations (**C**) so front of dock leveler will stay level with dock floor when leveler is resting fully on shims.

Note: Hoist cylinder and maintenance prop will be shimmed later in the install process.

INSTALLATION

Install Dock Leveler (continued)

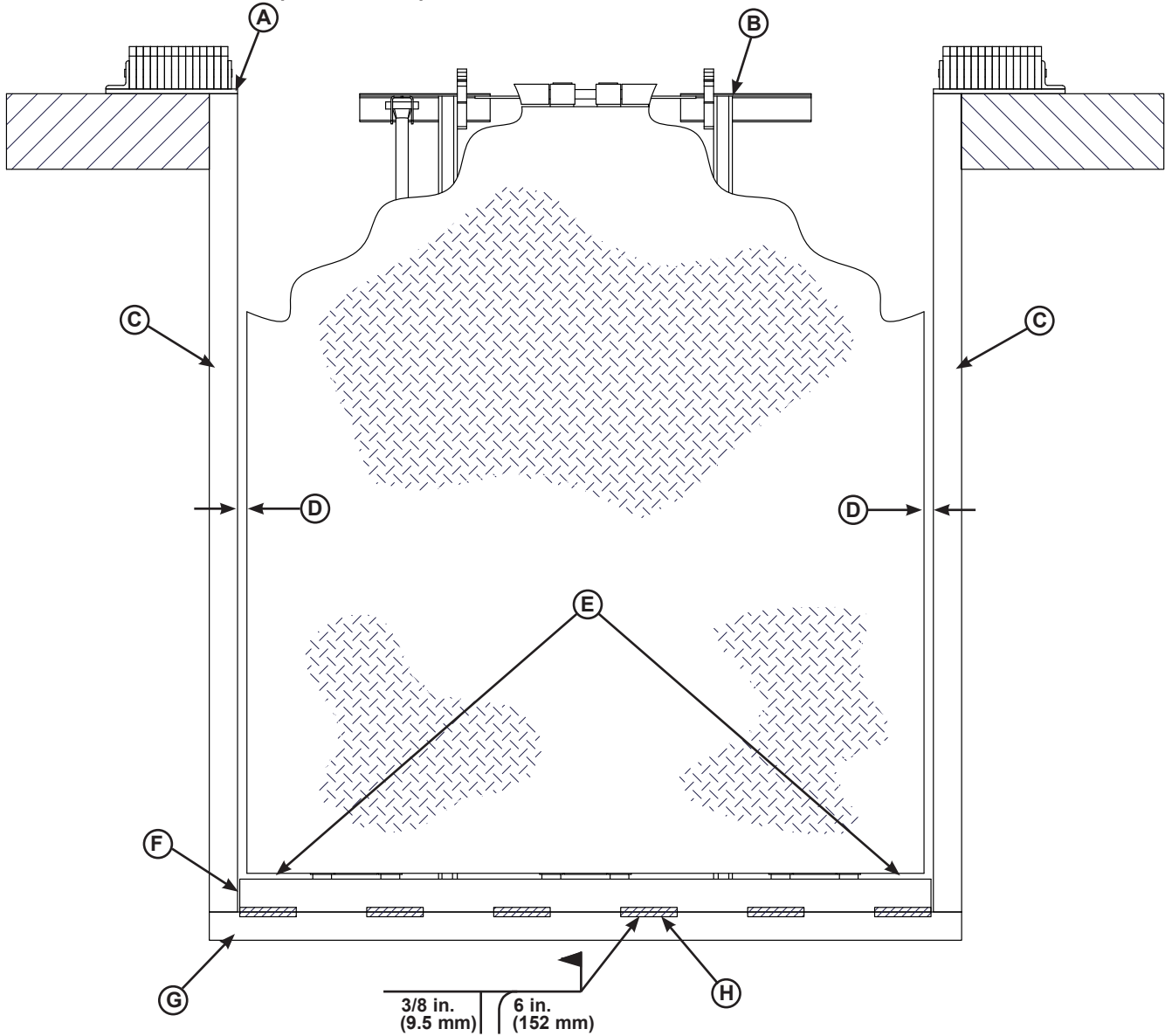

Figure 11

- | | | | |
|-----------------------|----------------------------------|---------------------------|---|
| A— Front of Dock Pit | C— Side Pit Curb Angle | E— Pry Locations | G— Rear Pit Curb Angle |
| B— Dock Leveler Frame | D— Gap [3/4 in. (19 mm) Minimum] | F— Rear Hinge Frame Angle | H— Flare Bevel Weld, Typical (To Fit Spacing) |

8. With rear hinge frame angle (F) tight against rear pit curb angle (G), perform/check the following:

- Pry between the platform and rear hinge frame angle at locations (E) to make sure rear edge of platform is parallel to the rear hinge frame angle (F).
- Gap (D) must exist equally along both sides of leveler so weather seal (if equipped) will not bind during dock leveler operation.

9. If gap (D) cannot be obtained equally at both sides of leveler, grind or add material at the rear edge of rear hinge frame angle (F) as needed.

10. Allow the dock leveler to rest fully on the shim stacks. Check that a smooth and level transition exists between the dock floor and the dock leveler platform. Add or remove shims as necessary until a smooth transition is obtained.

11. If leveler cannot be squared and/or made level as instructed in steps 8-10, contact Systems, LLC Technical Services.

Install Dock Leveler (continued)

NOTICE

DO NOT weld continuously along the full length of the rear hinge frame angle. This can put unnecessary stress on the leveler components, causing the leveler to malfunction and shorten the lifespan of the affected components.

12. With the rear hinge frame angle (**F**) tight against the rear pit curb angle (**G**), weld the rear hinge frame angle (**F**) to the rear pit curb angle (**G**) using a 3/8 in. (9.5 mm) flare bevel skip weld — each weld being 6 in. (152 mm) long.

- Start at each end with a 6 in. (152 mm) long weld. Space all the other welds out evenly, leaving approximately 6 in. (152 mm) space between each weld.

Note: Figure 11 shows a typical weld pattern. The weld pattern will vary slightly depending on size of dock leveler.

13. Weld front of dock leveler frame (**B**) to shims located under the keepers, then weld the shims to the front pit curb steel.

14. With leveler welded into place, remove the shipping bands from around lip and leveler frame.

15. Using an external lifting device (i.e. crane or fork truck) attached to the platform lifting brackets, slowly raise the platform. Check for binding as platform is being raised.

16. If binding occurs, lower the platform. Reposition leveler and/or add or remove shims as necessary. Slowly raise platform again. If platform still binds, contact Systems, LLC Technical Services for further instructions.

WARNING

If the platform is raised using an external lifting device or the hydraulic system is opened to atmosphere, air will enter into the hydraulic system.

Whenever this happens, always cycle the leveler at least 4 times using the leveler's own hydraulic power system before allowing the leveler to be put into service. This is to make sure all air is purged from the hydraulic cylinders.

INSTALLATION

Install Dock Leveler (continued)

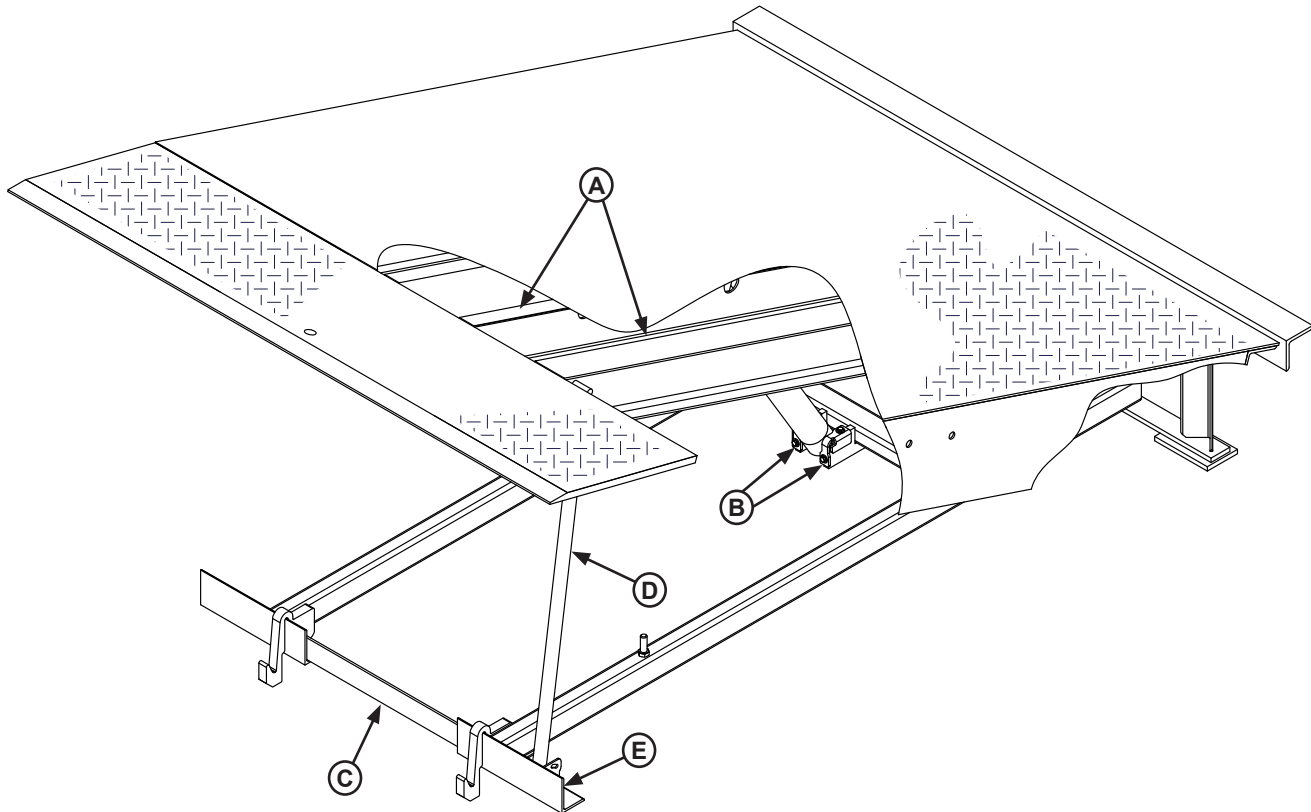

Figure 12

A — Platform Joists

B — Shim Location (Under Platform Cylinder Trunnions)

C — Removable “Clean Sweep” Frame Section

D — Maintenance Prop

E — Shim Location (Under Maintenance Prop)

17. Shim and weld the maintenance prop (Figure 12):

a. Install shims under maintenance prop (D) where prop attaches to leveler frame (E). Make sure prop is solidly shimmed.

b. Raise maintenance prop (D) to the service (upright) position and lock prop in this position using an OSHA approved locking device.

18. Install shims at locations (B and E) using an appropriate shimming method (see Figure 13). Both platform cylinder trunnions must be solidly shimmed the entire length of the trunnion. Make sure the trunnions are level from side-to-side as well as from front-to-back.

19. Finish weld all shims using a fillet weld:

- Weld all shims within each shim stack to each other, then weld the shim stack to the leveler frame.
- Weld the front leveler frame shim stacks to the front pit curb steel.

WARNING

DO NOT use the maintenance prop to support the raised platform until the maintenance prop has been properly shimmed and welded. The shims must be welded to each other, and also to the leveler frame.

WARNING

Make sure the platform is properly supported in the raised position before entering the pit to finish weld the shims.

Install Dock Leveler (continued)

20. When all welding has been completed, paint all the welds and shims.

Note: DH models are shipped with a front frame section (C) installed. This temporary frame holds the leveler frame at the correct dimensions until the leveler is permanently anchored into place. Only then should it be removed.

21. Remove the Clean Sweep frame section (C) by grinding the tack welds that hold it in place during transport. Paint after.

22. Install the dock bumpers as required.

23. Proceed to “Install Control Panel and Wiring” on Page 20.

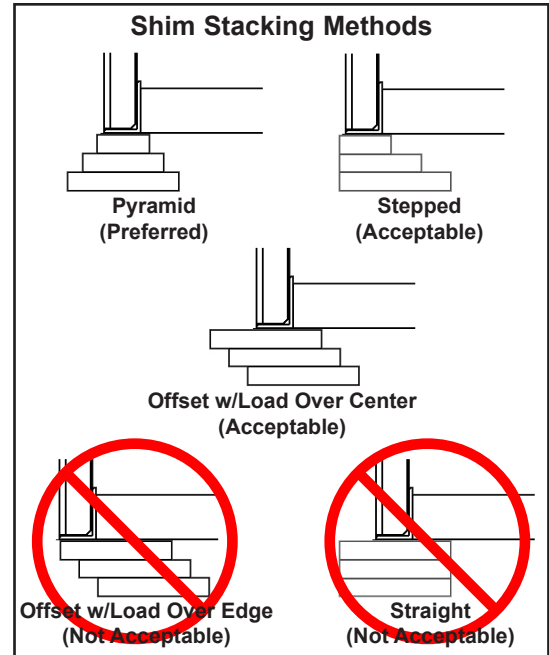

Figure 13

INSTALLATION

Install Control Panel and Wiring

DANGER

Make sure that the power source has been locked out and tagged according to OSHA regulations and approved local electrical codes.

NOTICE

DO NOT connect the dock leveler electrical wiring and ground connections until all welding has been completed.



DO NOT ground welding equipment to any hydraulic or electrical components of the dock leveler. Always ground welding equipment to the dock leveler frame, NEVER to the platform.

Failure to follow these instructions may damage the motor, hydraulics, wiring, and/or control panel.

CAUTION

All electrical work — including the installation of the disconnect panel, control panel, and final connections to the pit junction box — must be performed by a certified electrician and conform to all local and applicable national codes.

DANGER



Arc Flash and Shock Hazard
PPE [Personal Protection Equipment] Required

De-energize equipment before working on or inside. Do not open cover without appropriate PPE. Refer to NFPA 70E for PPE requirements. This panel may contain more than one power source.

Hazardous Voltage Will Result in Death or Serious Injury

1751-0736 Rev. A

NOTICE

Where indicated, all components must be connected to a SAFETY EARTH GROUND that conforms to the 1999 National Electrical Code Section 250-50 section (a) or section (c) for a grounding electrode system.

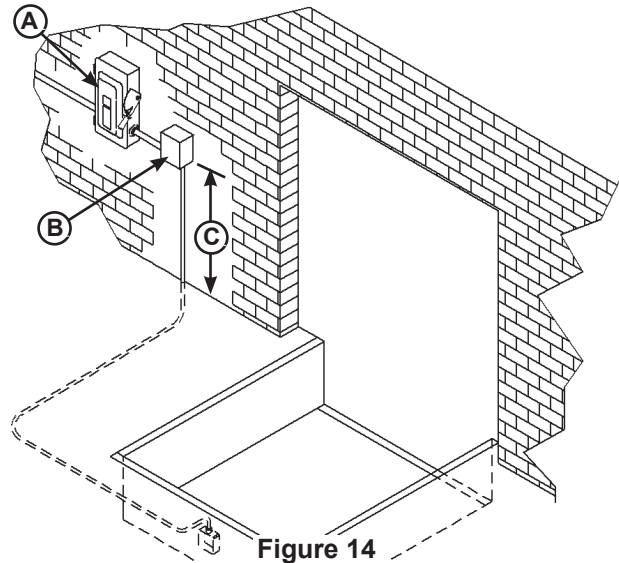

Figure 14

A— Disconnect Panel (provided by others)
B— Control Panel C— Distance, 48 in. (1219 mm)

1. Mount the push-button control panel (B) so bottom of control panel-to-dock floor distance (C) is 48 in. (1219 mm). See Figure 14.
2. Install electrical disconnect panel (A) if not already installed. Disconnect panel supplied by others.
3. Install and connect the control wiring (see page 21 for Danfoss push-buttons, or drawings supplied with equipment for Systems, LLC controls).
4. Connect the dock leveler power cable to the field wires in the pit junction box.
5. Seal the conduit in any location where the conduit crosses over temperature zones that could produce condensation.

Optional: Install spacers between the wall and enclosure to provide temperature insulation and air flow. If the conduit could fill with water, a drip leg may be needed.
6. Install placard (see page 22).

Danfoss Control Panel Wiring (1-Phase)

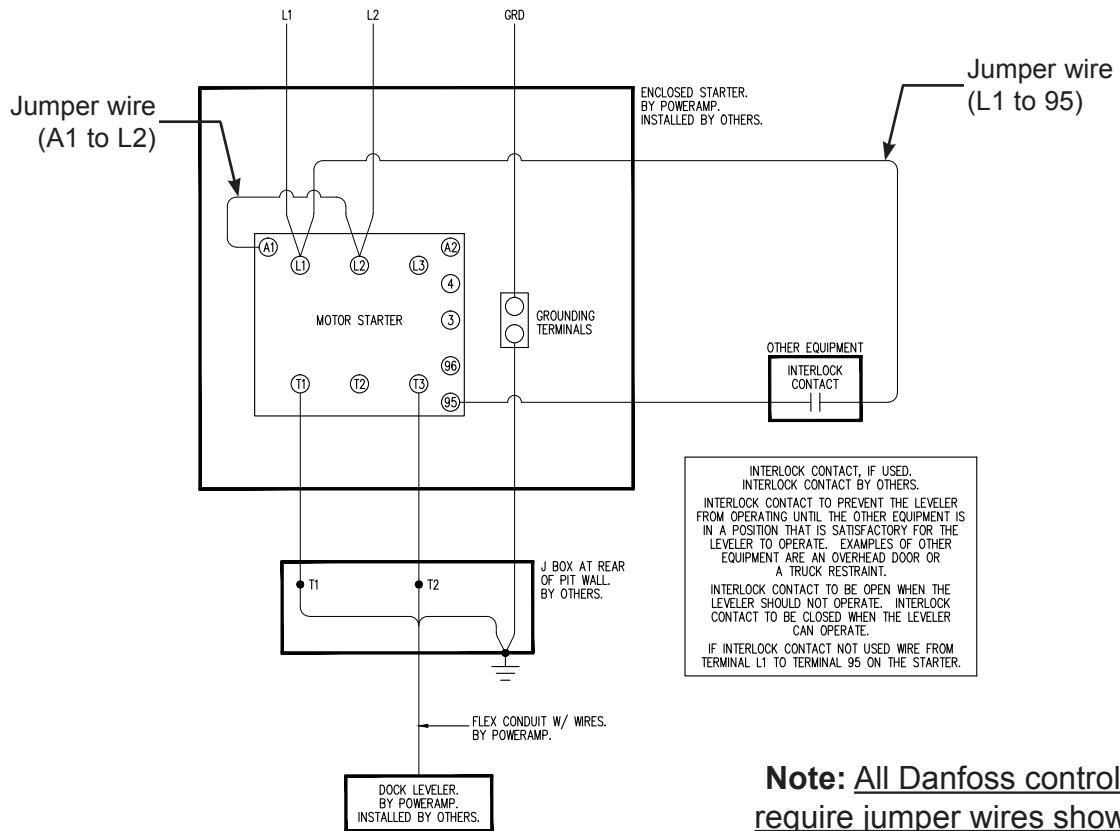

Danfoss Control Panel Wiring (3-Phase)

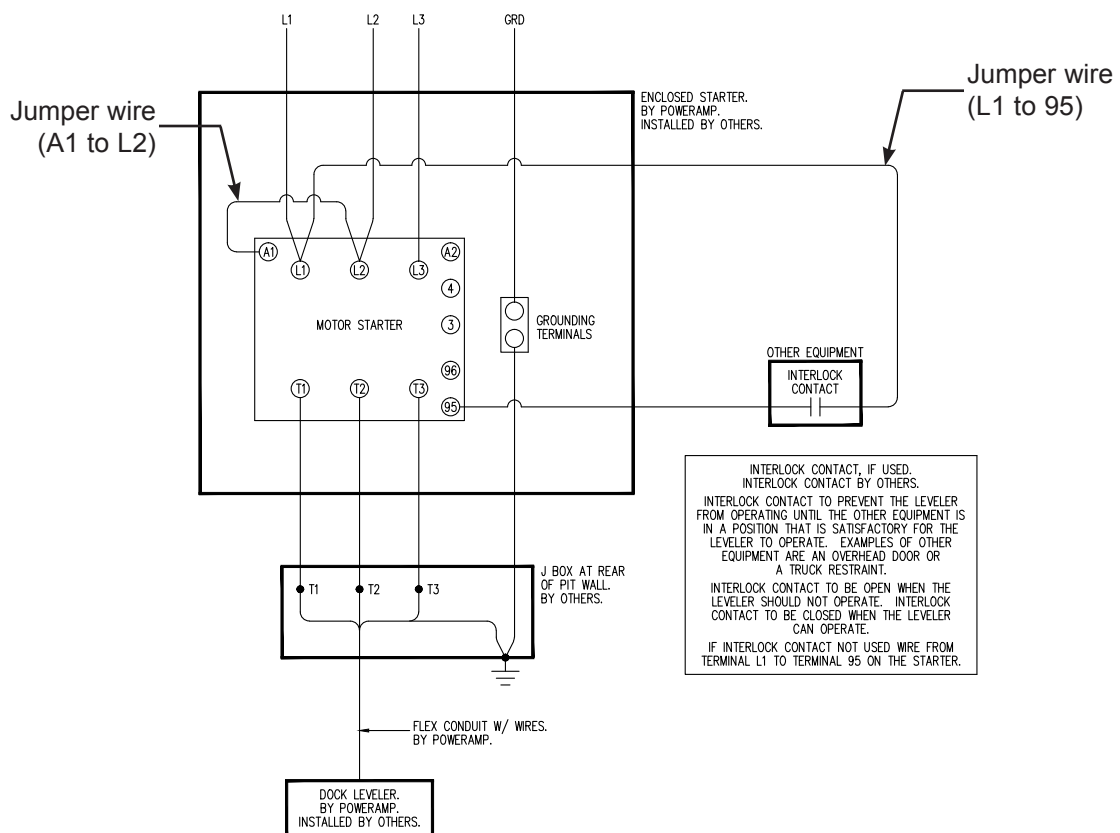

INSTALLATION

Placard Installation Instructions

- Owner/Users are responsible for the installation and placement of product placards.
- Make sure placard is in plain view of dock leveler and/or vehicle restraint operations.
- Suggested placement of placard is near control box attached to electrical conduit by using nylon cable tie. If there is no control box present, mount placard on wall to the immediate left of leveler at eye level.

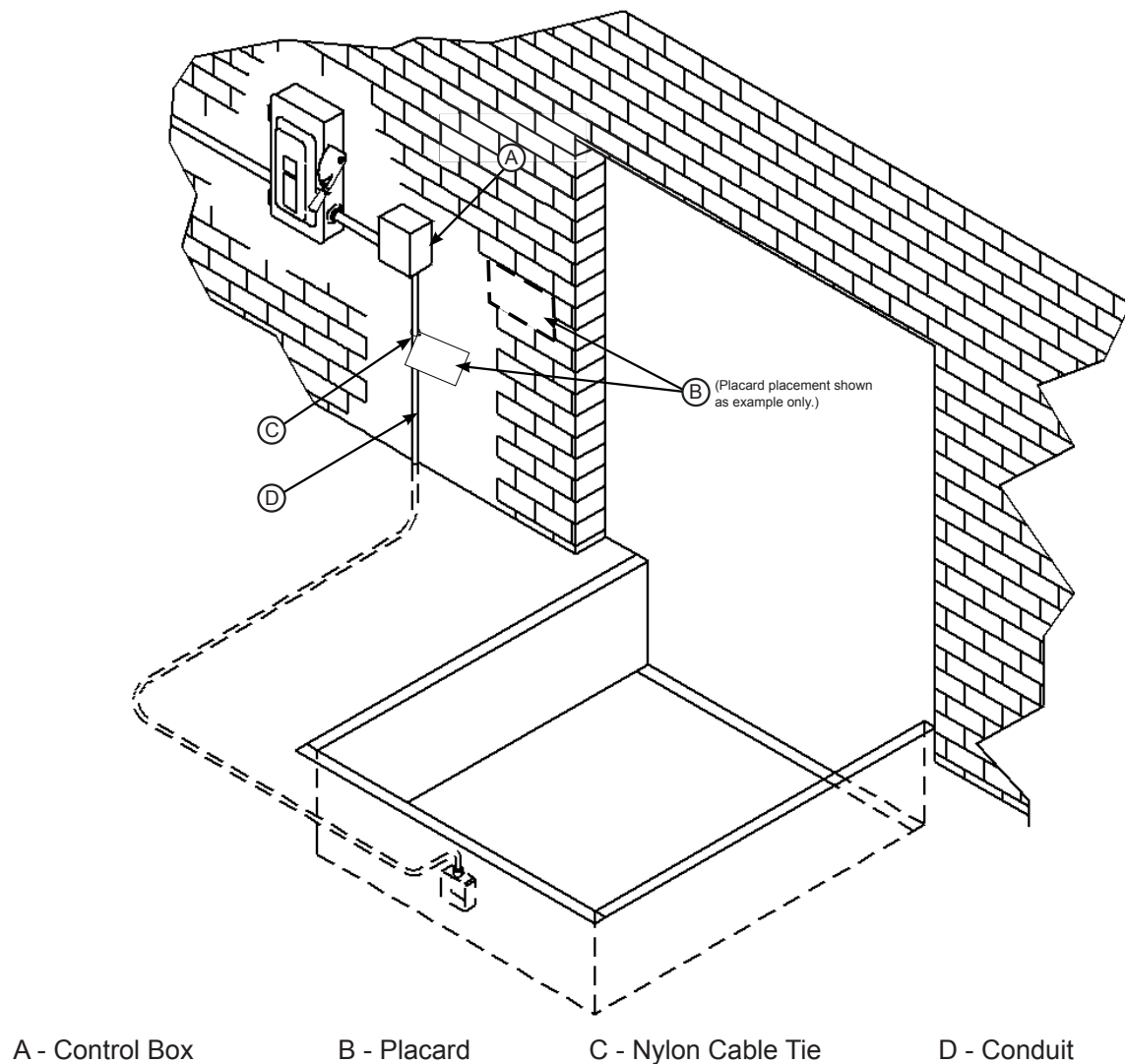

Figure 15

Put New Dock Leveler Into Service

WARNING

A hard hat or other applicable head protection should always be worn when working under or around a dock leveler.

Always stand clear of platform lip when working in front of the dock leveler.

1. Disconnect the external lifting device and chains from the lifting brackets.
2. Check that the leveler is flush with the dock floor and that the platform lip contacts both lip keepers evenly.

Note: If an excessive transition exists between the dock floor and leveler and/or lip does not contact both lip keepers evenly, contact Systems, LLC Technical Services for further instructions.

3. Turn the main electrical power ON.
4. Raise the leveler platform fully by Pressing and holding the RAISE button.

Note: The platform of a properly operating dock leveler will automatically stop rising when it reaches its maximum full raised height, at which point, the lip extends. When the lip is fully extended, the powerpack will go into pressure relief. (If the lip does not extend correctly, see Troubleshooting section.)

5. Release the RAISE button to lower the platform. As long as there is no vehicle present at the dock, the platform will lower to the full below-dock position as the lip folds.

Note: If a transport vehicle is present, the platform will lower until the lip rests on the transport vehicle's bed.

6. When the platform lowers to the full below-dock position, Press and hold the RAISE button until the platform rises just enough to clear the lip keepers, then release the RAISE button to allow the platform to lower to the cross-traffic (stored) position (lip engages lip keepers).

Note: For dock levelers equipped with the Auto Return To Dock (ARTD), the platform will automatically return to the cross-traffic position if the ARTD is enabled. When the platform is at the full below-dock position, there is a six-second delay before the platform will automatically rise to the cross-traffic position.

7. Perform steps 4-6 at least four times to purge any air that may be in the hydraulic system and to ensure proper operation.
8. Raise the platform fully. Hold the platform at this position using the RAISE button and move the maintenance prop to the service (upright) position. Release the RAISE button to allow the platform to lower until it is resting on the maintenance prop.

DANGER

Unless the dock leveler is equipped with a tethered remote, two people are required to engage the maintenance prop: one person to operate the unit, the other person to engage the maintenance prop.

In addition, it is recommended and good safety practice to use an additional means to support the dock platform and lip anytime when physically working in front of or under the dock leveler. This additional means may include, but is not limited to a boom truck, fork truck, stabilizing bar or equivalent.

9. Secure the maintenance prop with the maintenance prop lock-out.
10. With the maintenance prop supporting the platform, remove the lifting brackets.
11. Release the maintenance prop by unlocking the lock-out.
12. Press and hold the RAISE button until the maintenance prop drops to its stored position. Release the RAISE button and allow the platform to lower fully.

OPERATION

Operational Precautions

DANGER

Stay clear of dock leveler and vehicle restraint when transport vehicle is entering or leaving dock area.

DO NOT move or use the dock leveler or restraint if anyone is under or in front of leveler.

Keep hands and feet clear of pinch points. Avoid putting any part of your body near moving parts.

WARNING

Only trained personnel should operate the dock leveler.

DO NOT use a broken or damaged dock leveler. Make sure proper service and maintenance procedures have been performed on leveler before using.

Transport vehicle wheels must be chocked unless a vehicle restraint is used. Never remove the wheel chocks until loading/unloading is finished and transport driver has been given permission to leave.

Make sure platform lip rests on the transport vehicles bed with at least 4 in. (102 mm) of overlap.

Maintain a safe distance from side edges of leveler during the loading/unloading process.

WARNING

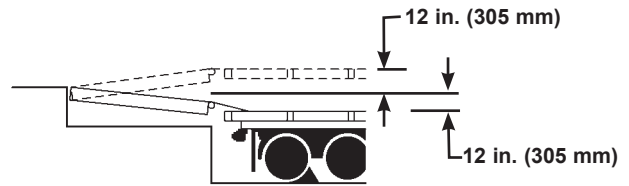

The DH hydraulic dock leveler is designed to compensate for a maximum ± 12 in.* (305 mm) of height difference between the loading dock and the transport vehicles bed. DO NOT use the dock leveler if the transport vehicles bed is more than 12 in. (305 mm) higher or lower than the dock floor.

*Service height may vary with design specifications

DO NOT overload the dock leveler.

DO NOT operate any equipment while under the influence of alcohol or drugs.

DO NOT leave equipment or material unattended on the dock leveler.

This page intentionally left blank.

OPERATION

Operating Instructions

Ramp Loading/Unloading

1. Before activating dock leveler, check to make sure the transport vehicle is positioned squarely against dock bumpers. Ensure lip will avoid contact with transport vehicle frame, sides and cargo during dock leveler activation. If contact is likely or observed, reposition transport vehicle.

2. Instruct driver to remain at the dock until the loading or unloading process has been completed.

3. Chock the transport vehicle wheels, or use a vehicle restraint if available.

4. Extend the dock leveler onto the transport vehicle as follows:

- a. Raise the platform by pressing and holding the RAISE button.
- b. Hold the RAISE button until the lip is fully extended, then release the RAISE button. The platform will lower until the lip is resting on the transport vehicle bed.
- c. Make sure that the lip is fully extended and supported on the transport vehicle along the entire width of the platform, with at least 4 in. (102 mm) of lip contacting the transport vehicle bed. See Figure 16.

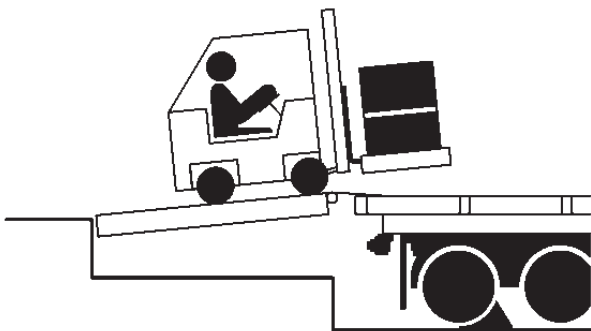

Figure 16

5. Proceed with loading or unloading the transport vehicle.

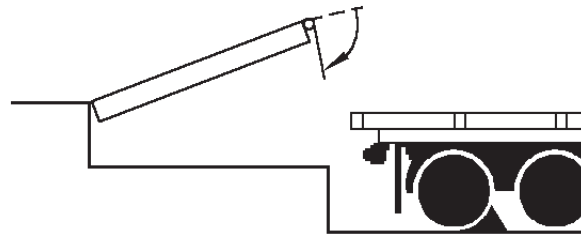

Figure 17

6. When loading or unloading is finished, raise the platform by pressing and holding the RAISE button until the lip folds enough to land in the lip keepers, then release the RAISE button. The platform will return to the cross-traffic position. See Figure 17.

7. Remove chocks from transport vehicle wheels, or release the vehicle restraint if used.

8. Indicate to driver that the transport vehicle may leave the dock.

Operating Instructions (continued)

End Loading/Unloading

1. Before activating dock leveler, check to make sure the transport vehicle is positioned squarely against dock bumpers. Ensure lip will avoid contact with transport vehicle frame, sides and cargo during dock leveler activation. If contact is likely or observed, reposition transport vehicle.

2. Instruct driver to remain at the dock until the loading or unloading process has been completed.

3. Chock the transport vehicle wheels, or use a vehicle restraint if available.

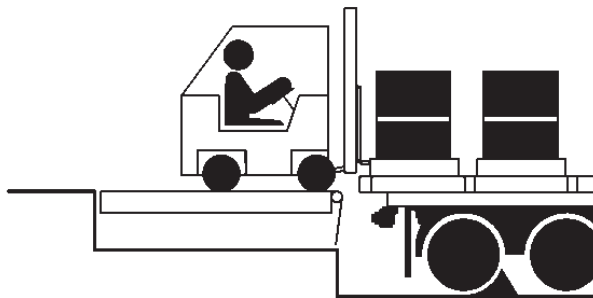

Figure 18

4. If transport vehicle bed is at or above dock floor level, leave leveler at the cross-traffic position and proceed with loading or unloading (see Figure 18). If transport vehicle bed is below the dock floor level, continue with Step 5.

5. Raise the platform by pressing and holding the RAISE button until the lip extends just enough to clear the lip keepers, then release the RAISE button.

6. Allow the platform to drift down to the full below-dock position.



Figure 19

7. Proceed with loading or unloading (see Figure 19).

Note: When end unloading is finished and access to the rest of the transport vehicles is still required, the platform lip will need to be extended. See Ramp Loading/Unloading Instructions on page 24 for further instructions.

8. When end loading or unloading is finished, raise the platform by pressing and holding the RAISE button until the lip folds enough to land in the lip keepers, then release the RAISE button. The platform will return to the cross-traffic position.

9. Remove chocks from transport vehicle wheels, or release the vehicle restraint if used.

10. Indicate to driver that the transport vehicle may leave the dock.

OPERATION

Optional Equipment

Quick Cycle Lip Extend (Lip Out)

Note: For dock levelers equipped with optional Quick Cycle Lip Extend/Lip Out, the dock leveler lip can be extended independently of the leveler platform with the following sequence:

1. Complete steps 1-4 in “Operating Instructions” on page 26.
2. When leveler has risen enough for lip to clear the transport vehicle bed, press and hold the LIP button in addition to the RAISE button. Leveler will stop raising and lip will extend.
3. When lip has fully extended, release RAISE and LIP buttons. Leveler will fall into transport vehicle with lip fully extended.
4. Continue with step 5 in “Operating Instructions.”

Emergency Stop (E-Stop)

Note: For dock levelers equipped with optional Emergency Stop (E-Stop), dock leveler can be halted in place by using the Emergency Stop button:

1. While operating any function of the dock leveler, press the EMERGENCY STOP button.
2. Equipment being operated will halt in place.
3. When hazard has been cleared or system must be operated, pull the EMERGENCY STOP button outward.

WARNING

When Emergency Stop is active, DO NOT go under the dock leveler, walk or drive on the dock leveler, or leave forklift and/or material sitting on the leveler!

If Emergency Stop button is pressed with the dock leveler unsupported in the working zone, the leveler will descend when E-Stop is released!

Always make sure the platform is properly supported in the raised position before entering the pit or going under the dock leveler.

4. Continue operating dock equipment as needed.

Auto Return To Dock (ARTD)

Note: For dock levelers equipped with optional Auto Return To Dock (ARTD), the dock leveler can self-store if a transport vehicle departs the loading dock before the platform is stored.

To enable Auto Return To Dock, turn the ARTD switch to the ON position. If end loading or unloading is required, turn the ARTD switch to the OFF position and follow the steps on page 27. When end loading or unloading is complete, turn the ARTD switch back to the ON position, and the dock leveler will self-store.

CAUTION

Whenever end loading or unloading with the platform in the below-dock position, make sure the ARTD switch is in the OFF position. DO NOT turn the ARTD switch to the ON position until end loading or unloading is finished.

Maintenance Precautions

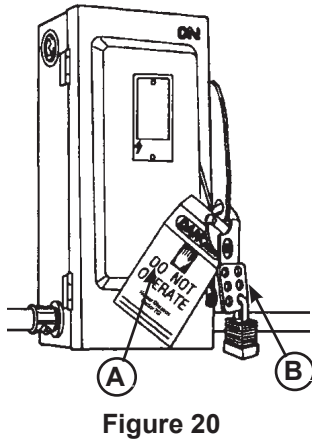

Figure 20

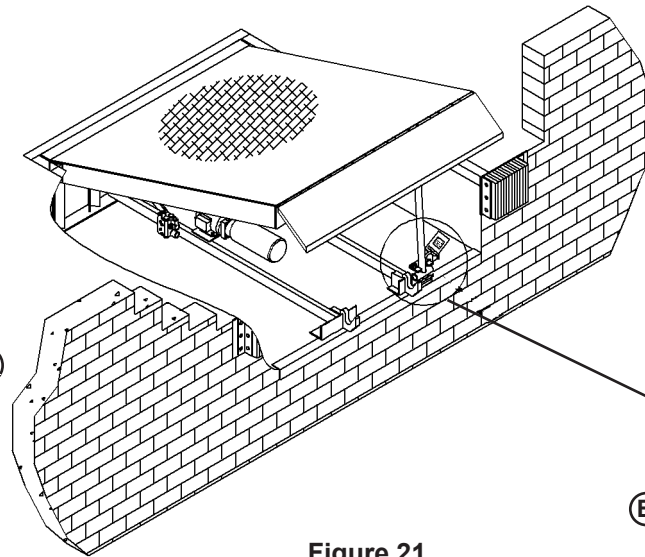

Figure 21

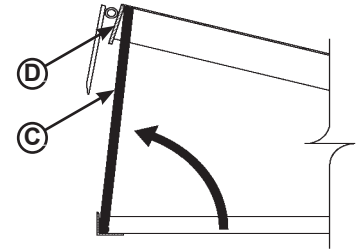

Figure 22

A— Tag Out Device B—Lock Out Device C— Maintenance Prop D— Header

! DANGER

Unless the dock leveler is equipped with a tethered remote, two people are required to engage the maintenance prop: one person to operate the unit, the other person to engage the maintenance prop.

In addition, it is recommended and good safety practice to use an additional means to support the dock platform and lip anytime when physically working in front of or under the dock leveler. This additional means may include, but is not limited to a boom truck, fork truck, stabilizing bar or equivalent.

When working with electrical or electronic controls, make sure that the power source has been tagged (A) and locked out (B) according to OSHA regulations and approved local electrical codes (see Figure 20).

Whenever maintenance is to be performed under the dock leveler platform, support the platform with maintenance prop (C). Position the maintenance prop behind front header plate (D) while staying clear of the lip. The lip will fold down after the platform has rested on the maintenance prop. Lock the maintenance prop in the service (upright) position using an OSHA approved lockout device* (B) and tag out device* (A). See Figures 21 and 22.

! WARNING

Always post safety warnings and barricade the work area at dock level and ground level to prevent unauthorized use of the unit before maintenance is complete.

Only the person servicing the equipment should have the capability to remove the lockout devices. The tag out devices* must inform that repairs are in process and clearly state who is responsible for the lockout condition.

! WARNING

A hard hat or other applicable head protection should always be worn when working under or around a dock leveler.

Always stand clear of platform lip when working in front of the dock leveler.

* Refer to OSHA regulations 1910.146. Confined Space and 1910.147. Lockout/Tagout

MAINTENANCE

Periodic Maintenance

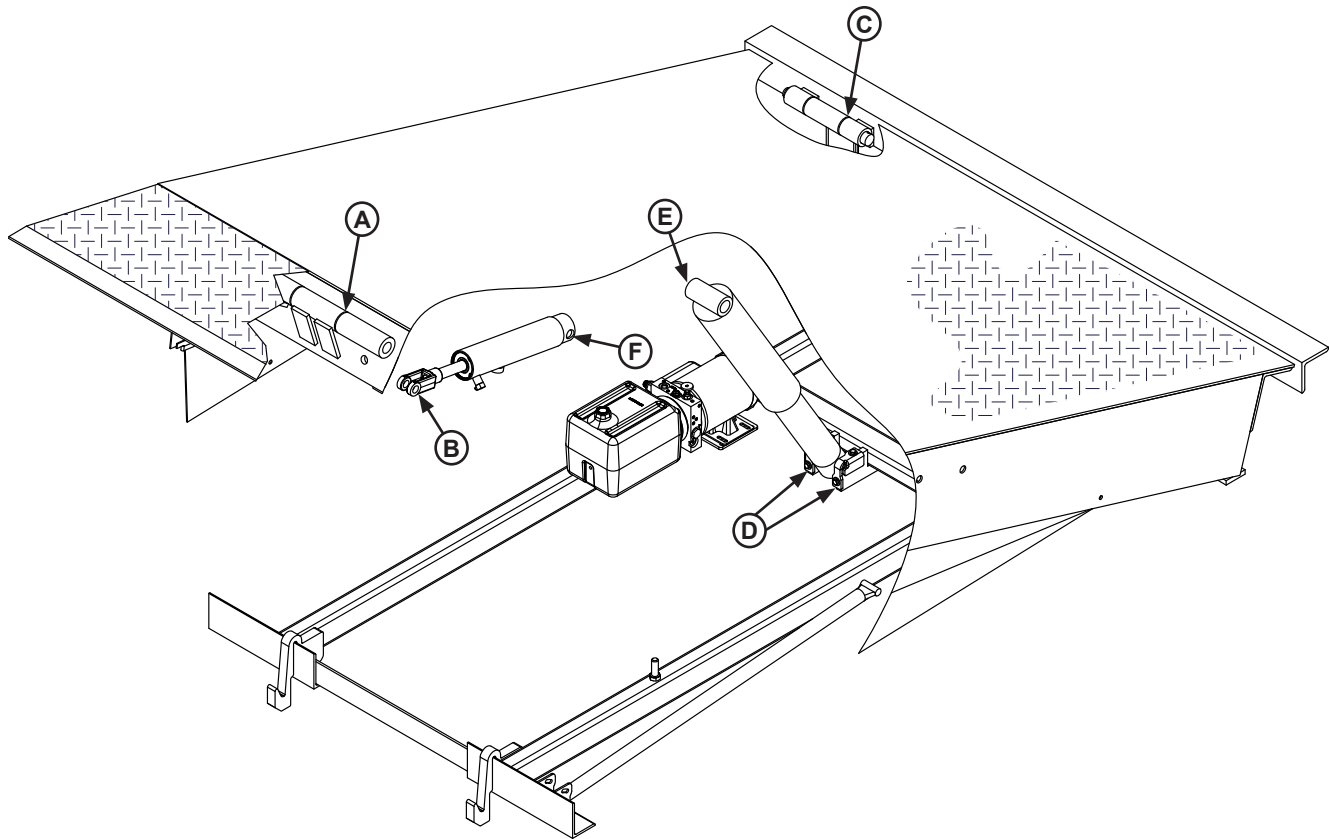

Figure 23

A— Lip Hinge Area
B— Lip Lifter and Lip Cylinder Pin

C— Platform Hinge Area
D— Platform Cylinder Trunnion

E— Platform Cylinder-to-Platform Pin
F— Lip Cylinder-to-Platform Frame Pin

To ensure normal operation of the dock leveler, use only aircraft hydraulic fluid designed to meet or exceed military specification MIL-H-5606-G. It is recommended that the following hydraulic fluids be used:

- ULTRA-VIS-HVI-15
- Aero Shell Fluid 4 or Fluid 41
- Mobile Aero HFA Mil-H5606A or Aero HF
- Texaco Aircraft Hydraulic Oil 15 or 5606
- Exxon Univis J13
- Castrol Brayco Micronic 756

These fluid brands can be mixed together. Use of hydraulic fluids with equivalent specifications to those listed here are acceptable.

NOTICE

Use of fluids that do not have equivalent specifications to those in the preceding list will result in abnormal operation of the dock leveler and voiding of warranty.

Weekly Maintenance

- Operate the dock leveler through the complete operating cycle to maintain lubrication.

Note: To thoroughly inspect the platform hinge area, put the platform in the full below-dock position.

- Inspect the platform hinge and the lip hinge areas. The hinge areas must be kept free of dirt and debris. Build-up of foreign material in the hinge areas will cause abnormal operation.
- Inspect warning decals and placards. Replace if damaged or missing.

Periodic Maintenance (continued)

Quarterly Maintenance

- Complete Weekly Maintenance.
- Inspect the following for damage/abnormal wear:
 - Check welds for cracks.
 - Cylinder pins and mounting holes.
 - Lip hinge pins and rear hinge pins.
 - Check toe guards for free movement.
 - Check J-box for water damage.
 - Inspect hoses, cylinders, fittings and powerpack.
 - Control box and conduit for damage.
 - Bumpers for more than 1" of wear. Replace worn, loose, damaged or missing bumpers.
 - Side and rear weather seals.
- Lubricate the following areas with light weight machine oil (see Figure 23):
 - (A)— Lip hinge area unless equipped with grease fittings (apply oil to the top of the entire length of lip hinge when platform is at the full below-dock position and lip is folded)
 - (B)— Lip lifter and lift cylinder pin
 - (C)— Platform hinge area (apply oil to top of all platform hinges when platform is at the full below-dock position)
 - (E)— Platform cylinder-to-platform frame pin
 - (F)— Lip cylinder-to-platform frame pin
- Lubricate the following areas with white lithium grease (see Figure 23):
 - (D) — All platform cylinder trunnions

Note: Apply grease to lip hinge grease fittings if equipped.

NOTICE

Failure to properly lubricate the dock leveler will cause abnormal operation of the leveler.

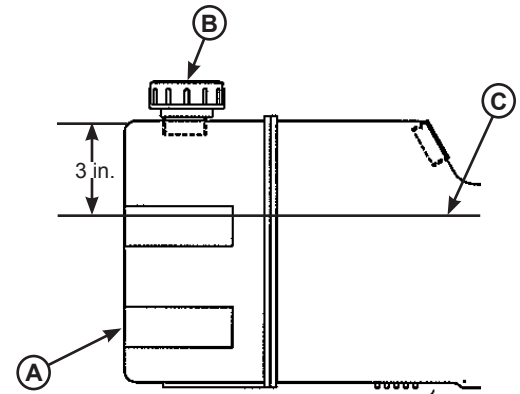

Figure 24

A - Reservoir **C - Fluid Level**
B - Breather Cap

- Check reservoir fluid level (C, see Figure 24):
 1. Raise platform fully and engage the maintenance prop in the service position. Allow platform to rest on the prop so the lip will fully fold until it contacts the lip stops.
 2. Turn OFF all electrical power to the leveler and lock out/tag out the electrical power supply.
 3. Remove breather cap (B).
 4. Measure fluid level. The fluid level should be approximately 3 in. (76.5 mm) from top of reservoir (C) with platform raised on the maintenance prop.
 5. Add hydraulic fluid if necessary. Use only recommended fluid (see page 30).
 6. Reinstall breather cap.
 7. Remove lock out/tag out and turn ON electrical power to the leveler.
 8. Return the platform to the cross-traffic position.

Yearly Maintenance

- Complete Quarterly Maintenance.
- Change hydraulic oil (may be required more often depending upon conditions).

ADJUSTMENTS

Valve Adjustments (Monarch/Bucher Powerpacks, 9/2010-present)

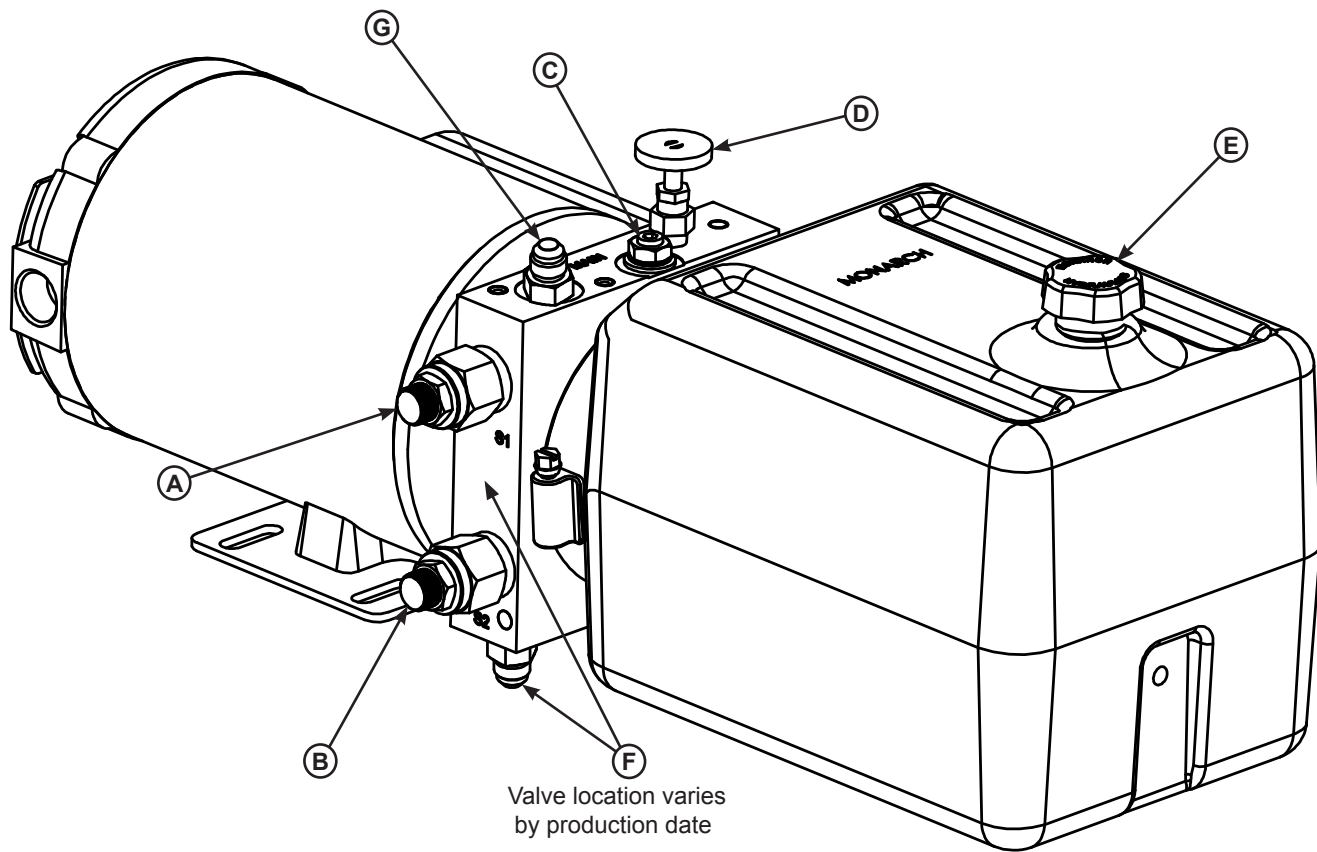

Figure 25

A— S1 Valve
B— S2 Valve

C— RV1 Valve
D— NV1 Valve

E— Breather Cap
F— To Hoist Cylinder

G— To Lip Cylinder

Valve Adjustments (Monarch/Bucher Powerpacks)

S1 Sequence Valve 1 (A)

Controls the Platform Cylinder. When the leveler has reached the top of its travel allow the leveler to float down. Fluid should flow through the NV1 valve. If you hear the motor spinning backwards, or Leveler and/or Lip may dropping prematurely adjust S1 clockwise in small increments, testing each time, until the motor is not spinning backwards or Leveler and/or Lip may drop correctly.

S2 Sequence Valve 2 (B)

Controls the Lip Cylinder. This valve should be set to allow a smooth, quiet shift. Turning S2 counter-clockwise causes the lip to extend.

If the lip does not extend turn S2 counter-clockwise out small increments until lip begins to extend. Once the lip is extended allow the powerpack to operate in pressure relief, then allow the leveler to return below dock.

Raise the leveler and continue to adjust the S2 valve to allow a smooth, quiet shift. When adjusted properly, the lip should stay extended until below dock. Lip extension cycle should not take more than a few seconds.

RV1 Main Relief Valve (C)

Sets system pressure. This valve has a security lock to prevent adjustment. Do not adjust unless specifically instructed by Systems, LLC Technical Services.

NV1 Needle Valve 1 (D)

Controls the Down speed of the ramp cylinder. Increase Down speed by turning NV1 counter-clockwise, Decrease Down speed by turning NV1 clockwise.

PO CHK Pilot Operated Check Valve (not shown)

Keeps Lip from collapsing until it is below dock. This valve is not adjustable. If lip malfunctions, cleaning or replacement may be required.

DANGER

Unless the dock leveler is equipped with a tethered remote, two people are required to engage the maintenance prop: one person to operate the unit, the other person to engage the maintenance prop.

In addition, it is recommended and good safety practice to use an additional means to support the dock platform and lip anytime when physically working in front of or under the dock leveler. This additional means may include, but is not limited to a boom truck, fork truck, stabilizing bar or equivalent.

WARNING

When service under the dock leveler is required, always lock all electrical disconnects in the OFF position after raising the platform and engaging the maintenance prop.

Always post safety warnings and barricade the work area at dock level and ground level to prevent unauthorized use of the dock leveler before maintenance is complete.

A hard hat or other applicable head protection should always be worn when working under or around a dock leveler.

Always stand clear of platform lip when working in front of the dock leveler.

NOTICE

All DLM DH dock levelers are factory tested, and should not require additional adjustments in the field. Consult Systems, LLC Technical Services if minor adjustments do not result in proper operation.

Whenever valve adjustments are completed, record the number of turns made to allow an undesirable adjustment result to be reversed.

ADJUSTMENTS

Valve Adjustments (Hoke/KTI Powerpacks, pre-9/2010)

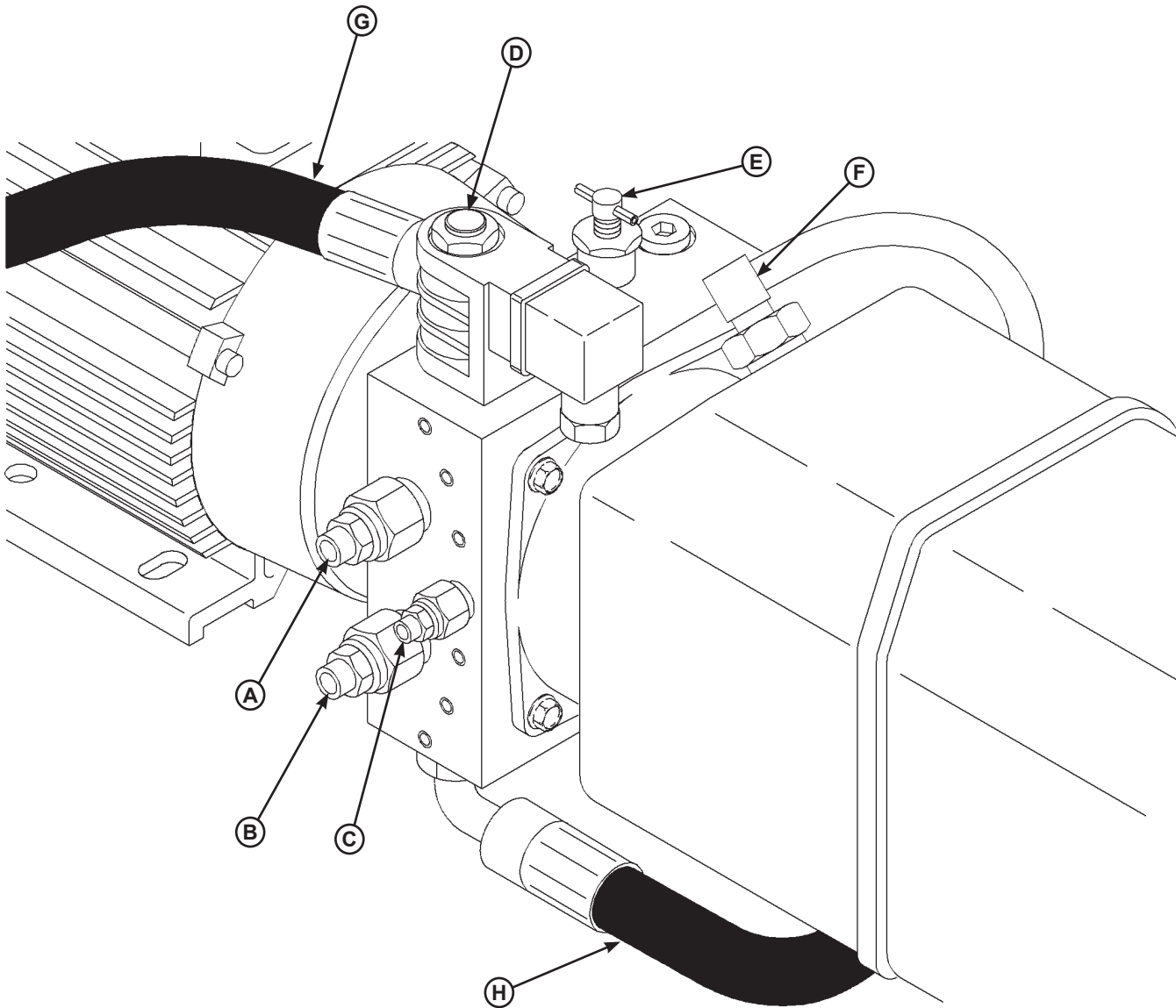

Figure 26

A—S1 Valve
B— S2 Valve

C—RV1 Valve
D— 2W NO Spool Valve

E— NV1 Valve
F— Breather Tube/Fitting

G—To Hoist Cylinder
H—To Lip Cylinder

Note: Not pictured (on the bottom of the valve body) are the RV2 and PO Check Valves

Valve Adjustments (Hoke/KTI Powerpacks)

S1 Sequence Valve 1 (A)

Controls the Platform Cylinder. When the leveler has reached the top of its travel allow the leveler to float down. Fluid should flow through the NV1 valve. If you hear the motor spinning backwards, or Leveler and/or Lip may dropping prematurely adjust S1 clockwise in small increments, testing each time, until the motor is not spinning backwards or Leveler and/or Lip may drop correctly.

S2 Sequence Valve 2 (B)

Controls the Lip Cylinder. This valve should be set to allow a smooth, quiet shift. Turning S2 counter-clockwise causes the lip to extend.

If the lip does not extend turn S2 counter-clockwise out small increments until lip begins to extend. Once the lip is extended allow the powerpack to operate in pressure relief, then allow the leveler to return below dock.

Raise the leveler and continue to adjust the S2 valve to allow a smooth, quiet shift. When adjusted properly, the lip should stay extended until below dock. Lip extension cycle should not take more than a few seconds.

RV1 Main Relief Valve (C)

Sets system pressure. This valve has a security lock to prevent adjustment. Do not adjust unless specifically instructed by Systems, LLC Technical Services.

Optional: 2W Normally Open Spool Valve (D)

If present, allows operation of Lip Out and Emergency Stop functions when solenoid coil is energized.

NV1 Needle Valve 1 (E)

Controls the Down speed of the ramp cylinder. Increase Down speed by turning NV1 counter-clockwise, Decrease Down speed by turning NV1 clockwise.

RV2 Relief Valve 2 (not shown)

Allows the lip to collapse below dock, protects the lip if it is backed in to. Set the RV2 valve by backing out adjustment screw as far as it goes.

Return leveler to keepers and begin to raise it. Halfway up, allow the leveler to return for a second, then raise leveler. The lip should not extend. If lip extends, turn S2 valve clockwise 1/4 turn and repeat until lip does not extend.

NOTICE

All DLM DH dock levelers are factory tested, and should not require additional adjustments in the field. Consult Systems, LLC Technical Services if minor adjustments do not result in proper operation.

Whenever valve adjustments are completed, record the number of turns made to allow an undesirable adjustment result to be reversed.

PO Pilot Operated Check Valve (not shown)

Keeps Lip from collapsing until it is below dock. This valve is not adjustable. If lip malfunctions, cleaning or replacement may be required.

ADJUSTMENTS

Adjust Auto Return To Dock (ARTD)

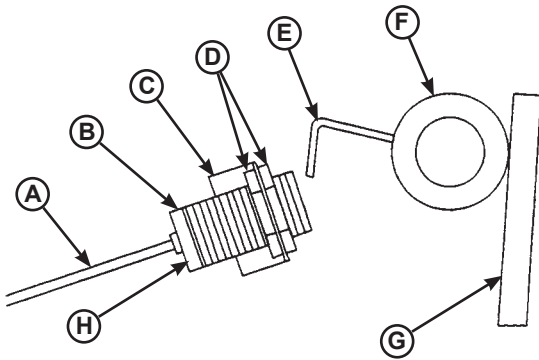

Figure 27

- | | |
|---------------------|--------------------|
| A— Cable | E— Target |
| B— Proximity Switch | F— Lip Hinge Tube |
| C— Bracket | G— Platform Lip |
| D— Lock Nuts | H— Indicator Light |

Auto Return To Dock (ARTD)

EH levelers can be equipped with optional Auto Return To Dock (ARTD) if leveler is not interlocked with a transport vehicle restraint.

The ARTD uses a proximity switch (**B**) located under the platform and a piece of angled steel called the target (**E**) that is attached to the lip hinge tube (**F**). See Figure 27.

The proximity switch provides a six-second delay after the platform has lowered to the full below-dock position, after which the platform will return to the cross-traffic position. The switch also contains an indicator light (**H**) that can be used for diagnosing and adjusting the switch.

Note: Some proximity switches have an indicator light at the back of the housing and some have the light at the side of the housing.

Adjust Auto Return To Dock (ARTD, continued)

NOTICE

Whenever proximity switch and target are adjusted, check for interference between target and switch before operating the leveler. Damage to switch will occur if the target contacts the switch.

The maximum torque for proximity switch lock nuts is 27 N·m (29 lb-ft). Damage to switch will occur if maximum torque is exceeded.

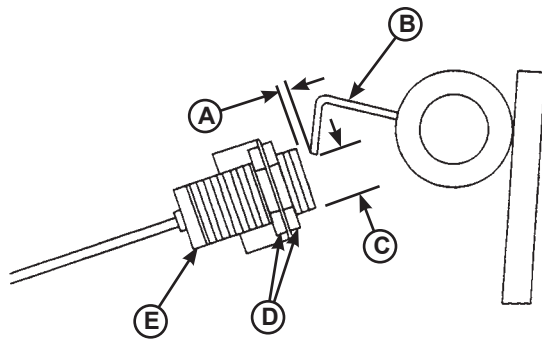

Figure 28

A— 1/4 in. (6.4 mm)
Approximate
B— Target

C— 1 in. (25.4 mm)
Approximate
D— Lock Nuts
E— Proximity Switch

Note: Distances (A and C) in Figure 28 are typical factory settings. Use these dimensions only as a starting point when adjusting the proximity switch and target, especially if switch and/or target have been replaced.

When dimensions (A and C) are obtained, the proximity switch and target may need finer adjustments to get the ARTD to operate as desired.

Adjust Auto Return To Dock (ARTD)

1. Raise platform fully and engage the maintenance prop in the service position. Allow platform to rest on the prop so the lip will fully fold until it contacts the lip stops.
2. Turn OFF all electrical power to the leveler and lock out/tag out the electrical power supply.
3. Loosen lock nuts (D). Adjust proximity switch (E) to obtain distance (A). Tighten lock nuts.
4. Bend target (B) as needed to obtain distance (C). Recheck distance (A) and readjust if necessary.

Note: At least two people may be required to manually move the lip.

5. After adjusting proximity switch and target, slowly move the lip up by hand while observing the target and proximity switch. The target **MUST NOT** contact the switch, otherwise, damage to switch will occur. Readjust switch and/or target if necessary, then recheck for interference.

6. Remove lock out/tag out and turn ON electrical power to the leveler.

7. Disengage the maintenance prop.

8. Turn the ARTD switch (on control panel) to the ON position.

9. Raise the platform until the lip is fully extended, then allow the platform to drift to the below-dock position. After approximately 6 seconds, the platform should return to the cross-traffic position.

10. Adjust the proximity switch and target as necessary. Make small adjustments, then operate the dock leveler to check results. Do this until satisfied with the ARTD operation.

Note: Use the illustrations on pages 36-37 to assist in fine tuning and/or diagnosing the ARTD operation.

ADJUSTMENTS

Adjust Auto Return To Dock (ARTD, continued)

Full Below-Dock Position

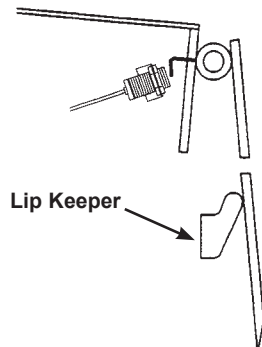

Figure 29

Whenever the platform lip is at the full below-dock position, the following conditions will exist for a normally operating ARTD (see Figure 29):

- Target in sensing area of proximity switch.
- Proximity switch ON (closed, signal sent to the control panel).
- Proximity switch indicator light is ON.
- Platform will automatically rise after approximately a six-second delay, then return to the cross-traffic position.

Lip Fully Extended Position

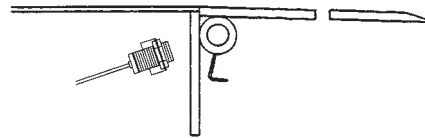

Figure 30

Whenever the platform lip is at the fully extended position, the following conditions will exist for a normally operating ARTD (see Figure 30):

- Target not in the sensing area of proximity switch.
- Proximity switch OFF (open, no signal sent to the control panel).
- Proximity switch indicator light is OFF.
- If the platform lip is resting on the transport vehicle bed, the platform will stay at this position unless the operator activates the leveler.

Cross-Traffic/Lip Fully Folded Position

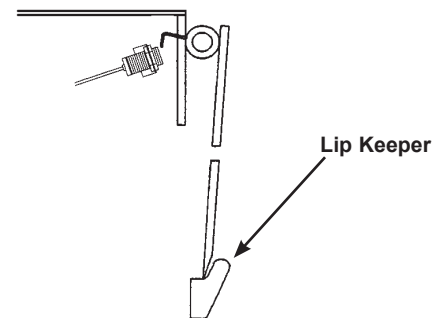

Figure 31

Note: The platform lip is fully folded when the platform is at the cross-traffic position (stored, with lip engaged with keepers) or when platform is resting on the maintenance prop.

Whenever the platform lip is at the cross-traffic or fully folded position, the following conditions will exist for a normally operating ARTD (see Figure 31):

- Target not in the sensing area of proximity switch.
- Proximity switch OFF (open, no signal sent to control panel).
- Proximity switch indicator light is OFF.
- Platform stays at this position unless the operator activates the leveler.

This page intentionally left blank.

TROUBLESHOOTING

DANGER

Unless the dock leveler is equipped with a tethered remote, two people are required to engage the maintenance prop: one person to operate the unit, the other person to engage the maintenance prop.

In addition, it is recommended and good safety practice to use an additional means to support the dock platform and lip anytime when physically working in front of or under the dock leveler. This additional means may include, but is not limited to a boom truck, fork truck, stabilizing bar or equivalent.

WARNING

When service under the dock leveler is required, always lock all electrical disconnects in the OFF position after raising the platform and engaging the maintenance prop.

Always post safety warnings and barricade the work area at dock level and ground level to prevent unauthorized use of the dock leveler before maintenance is complete.

A hard hat or other applicable head protection should always be worn when working under or around a dock leveler.

Always stand clear of platform lip when working in front of the dock leveler.

Before performing the detailed troubleshooting procedures, check the following items first:

- Check all fuses inside the control panel(s). Replace any blown fuse(s) with a fuse of equal specification.
- Make sure the correct voltages are present at the proper locations inside the control panel(s).

Symptom	Possible Cause	Solution
Platform does not rise. Motor does not energize.	Motor overload device tripped.	Reset overload relay or breaker. Determine cause of device tripping.
	Motor starter (three-phase) or motor relay (single-phase) not energizing.	Check voltage at starter or relay coil. <ul style="list-style-type: none"> • If voltage is present and starter or relay does not energize, replace starter or relay. • If voltage is not present, check all components in series with the starter or relay coil.

TROUBLESHOOTING

Symptom	Possible Cause	Solution
Three-phase units only: Platform does not rise. Motor hums, but does not run.	No voltage is present on one line. <i>NOTE: A motor that is missing voltage on one line is said to be single-phased.</i>	Check for blown fuses at branch circuit disconnect. Replace fuse. Determine cause of blown fuse.
		Check motor starter as follows: 1. Disconnect wires at load side of starter. 2. Energize the starter. 3. Measure line-to-line voltage at line side of starter. 4. Measure line-to-line voltage at load side of starter. 5. Line-side and load-side voltages should be approximately the same. Replace starter if voltage values are considerably different from one another.
		Check all wiring to motor for high resistance or no connection.
Three-phase units only: Platform does not rise. Motor runs in reverse	Phase reversed.	Reverse any two legs at the branch circuit disconnect.
Single-phase units only: Platform does not rise. Motor energizes, but does not run.	Line voltage too low.	Check wiring to motor for high resistance. Check for loose or corroded connections. Check if gauge of wires to motor are of correct size and specification for load requirement. Replace if necessary.
	Faulty motor centrifugal switch.	Replace motor.
	Faulty motor capacitor.	Replace motor.
Units equipped with ARTD only: Platform does not automatically return to the cross-traffic position or operates abnormally.	Auto return proximity switch not sensing target correctly.	Adjust proximity switch and target as necessary. See Adjust Auto Return To Dock (ARTD) on pages 36-38.
	Faulty proximity switch.	Replace switch.
	Loose/corroded wire connections or broken wire.	Repair or replace wires and connections as necessary.

TROUBLESHOOTING

Symptom	Possible Cause	Solution
Platform does not rise. Pump operates in pressure relief mode.	Heavy object(s) on platform.	Remove object(s) from platform. Note: For safety reasons, the dock leveler is designed to lift only the platform's own weight.
	Dock leveler binds.	Check for visible obstructions that could cause binding. Remove obstructions. If no obstructions found, contact Systems, LLC Technical Services.
	Pressure relief set too low.	Increase pressure relief. Contact Systems, LLC Technical Services for instruction. Note: The pressure relief valve must not be set at a level that causes the motor operating current to exceed the full load amp value* at any time, including when operating in pressure relief. <i>* The full load amp value can be found on the inside cover of the control panel.</i>
Platform rises slowly.	Low hydraulic fluid.	Add fluid, see pages 30-31 for proper fluid level and type.
	Contaminated hydraulic system.	Clean and inspect valves. Flush contaminated oil from hydraulic system. Fill system with new oil. See page 31..
	Damage or blocked hydraulic hose(s) and/or valve(s).	Replace damaged hose(s). Check and remove blockage from hose(s) and/or valve(s).
	Pressure relief set too low.	Increase pressure relief. Contact Systems, LLC Technical Services for instruction. Note: The pressure relief valve must not be set at a level that causes the motor operating current to exceed the full load amp value* at any time, including when operating in pressure relief. <i>* The full load amp value can be found on the inside cover of the control panel.</i>
Pump motor loads down when platform reaches the full raised position.	Pressure relief set too high.	Decrease pressure relief. Contact Systems, LLC Technical Services for instruction. Note: The pressure relief valve must not be set at a level that causes the motor operating current to exceed the full load amp value* at any time, including when operating in pressure relief. <i>* The full load amp value can be found on the inside cover of the control panel.</i>

TROUBLESHOOTING

Symptom	Possible Cause	Solution
Platform does not rise to full height.	Low hydraulic fluid.	Add fluid, see pages 30-31 for proper fluid level and type.
Lip does not stay extended when leveler lowers.	S1 Sequence Valve requires adjustment.	Adjust valve as necessary. See pages 32-35 for adjustment instructions.
Platform DOES rise to full height, but lip DOES NOT extend or extend fully.	Low hydraulic fluid.	Add fluid, see pages 30-31 for proper fluid level and type.
	S2 Sequence Valve 2 requires adjustment.	Adjust valve as necessary. See pages 32-35 for adjustment instructions.
Lip does not extend.	S2 Sequence Valve 2 requires adjustment.	Adjust valve as necessary. See pages 32-35 for adjustment instructions.
Lip extends almost immediately when the RAISE button is Pressed. Platform rises after lip is fully extended.	S2 Sequence Valve 2 requires adjustment.	Adjust valve as necessary. See pages 32-35 for adjustment instructions.
Platform locks into “safety” as platform lowers. Lip drops to vertical position.	Platform lowering speed is too fast; NV1 Needle Valve 1 requires adjustment	Adjust valve as necessary. See pages 32-35 for adjustment instructions.
	Faulty velocity fuse.	Replace velocity fuse.
	Incorrect or aged hydraulic fluid.	Replace hydraulic fluid, see pages 30-31 for proper fluid level and type.

If additional troubleshooting assistance is required, contact Systems, LLC Technical Services with equipment serial number or customer order number (CO#).

Technical Service at 800-643-5424 or techservices@loadingdocksystems.com

PARTS

Danfoss Control Box



Part Number	Voltage	Phase	Description
7141-0268	110v	1-Phase	Danfoss Control Box (MTR 3627A)
7141-0329	208v	1-Phase	Danfoss Control Box (MTR 3627B)
7141-0269	230v	1-Phase	Danfoss Control Box (MTR 3627C)
7141-0310	208v	3-Phase	Danfoss Control Box (MTR 3627D)
7141-0270	230v	3-Phase	Danfoss Control Box (MTR 3627E)
7141-0271	460v	3-Phase	Danfoss Control Box (MTR 3627F)

* Provide dock leveler serial number, voltage, phase, and options when e-mailing, calling or faxing controller orders.

Optional Electrical Parts

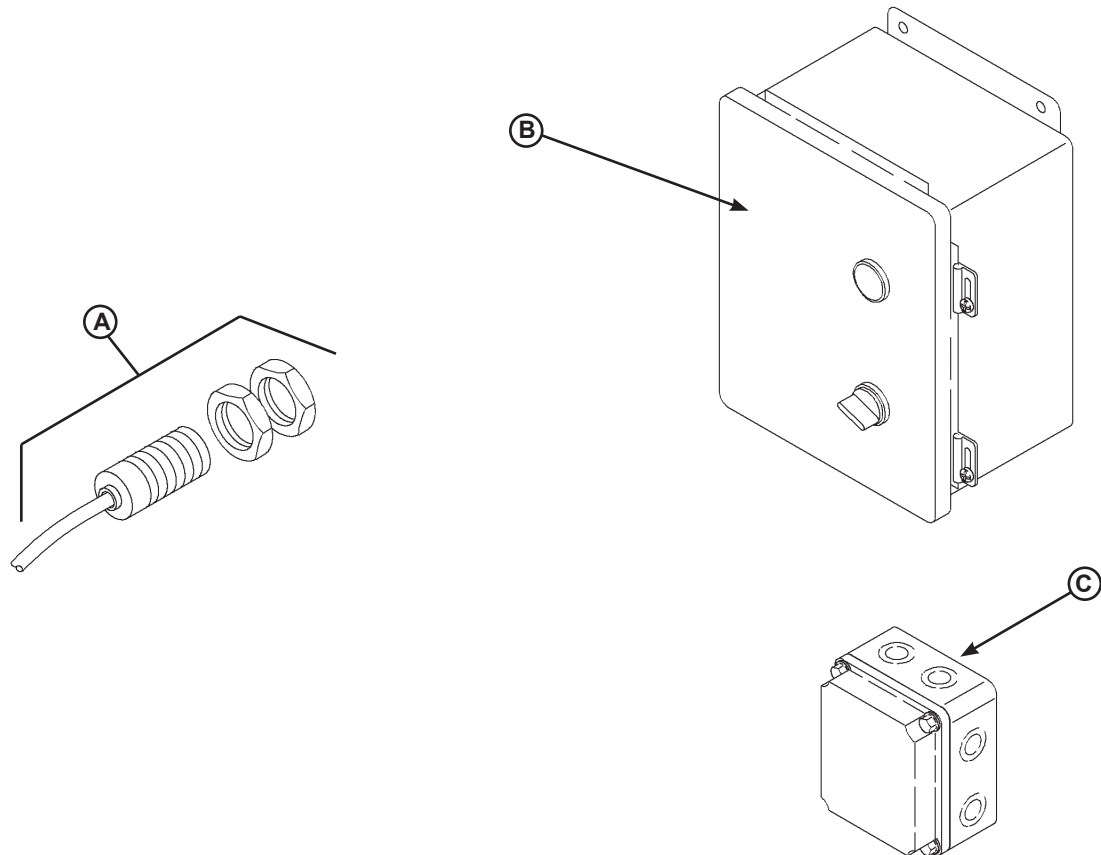

Item	Quantity	Part Number	Description
A	1	0961-0085	Proximity Switch with Harness (ARTD Feature Only)
B	1	*	Control Box w/Optional Equipment
C	1	9511-0004	J-Box, Standard (4 x 4 in. Metal Box)
		2751-0042	J-Box, Cold Weather (5 x 5 in. Plastic Box)

* Provide dock leveler serial number, voltage, phase, and options when e-mailing, calling or faxing controller orders.

PARTS

Frame and Platform

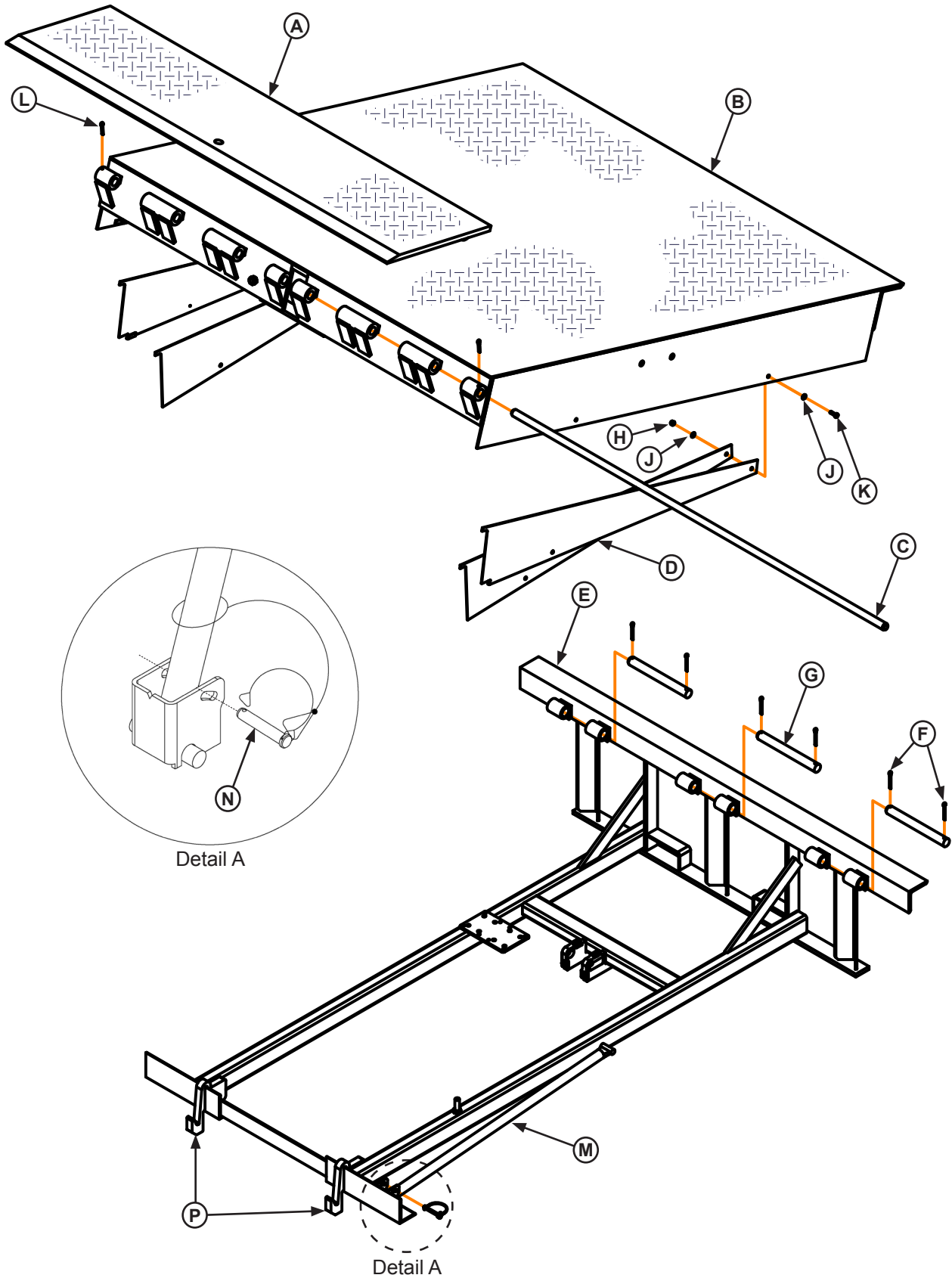

Frame and Platform

Item	Quantity	Part Number	Description
A	1	0595-____ ¹	Lip, Welded Assembly
B	1	7823-____ ²	Platform, Welded Assembly
C	1	9515-____ ¹	Pin, Lip Hinge
D	1	See Page 55	Toe Guards
E	1	9202-____ ¹	Frame, Welded Assembly
F	6	2101-0047	Cotter Pin, 1/4 x 2 in.
G	3	9202-0002	Rear Hinge Pin
H	AR	2101-0039	Nylon Lock Nut, 5/16-18 UNC
J	AR	2101-0163	Washer, 5/16 in., Flat
K	AR	2101-0011	Cap Screw, 5/16-18 UNC x 1 in.
L	2	2101-0046	Cotter Pin, 1/4 x 1-1/4 in.
M	1	9225-____ ¹	Maintenance Prop Rod
N	1	9201-0006	Prop Pin and Clip
P	2	8432-____ ¹	Lip Keeper

AR = As Required

¹ Provide dock leveler serial number, platform size, and lip size when e-mailing, calling or faxing orders.

PARTS

Hydraulic Components

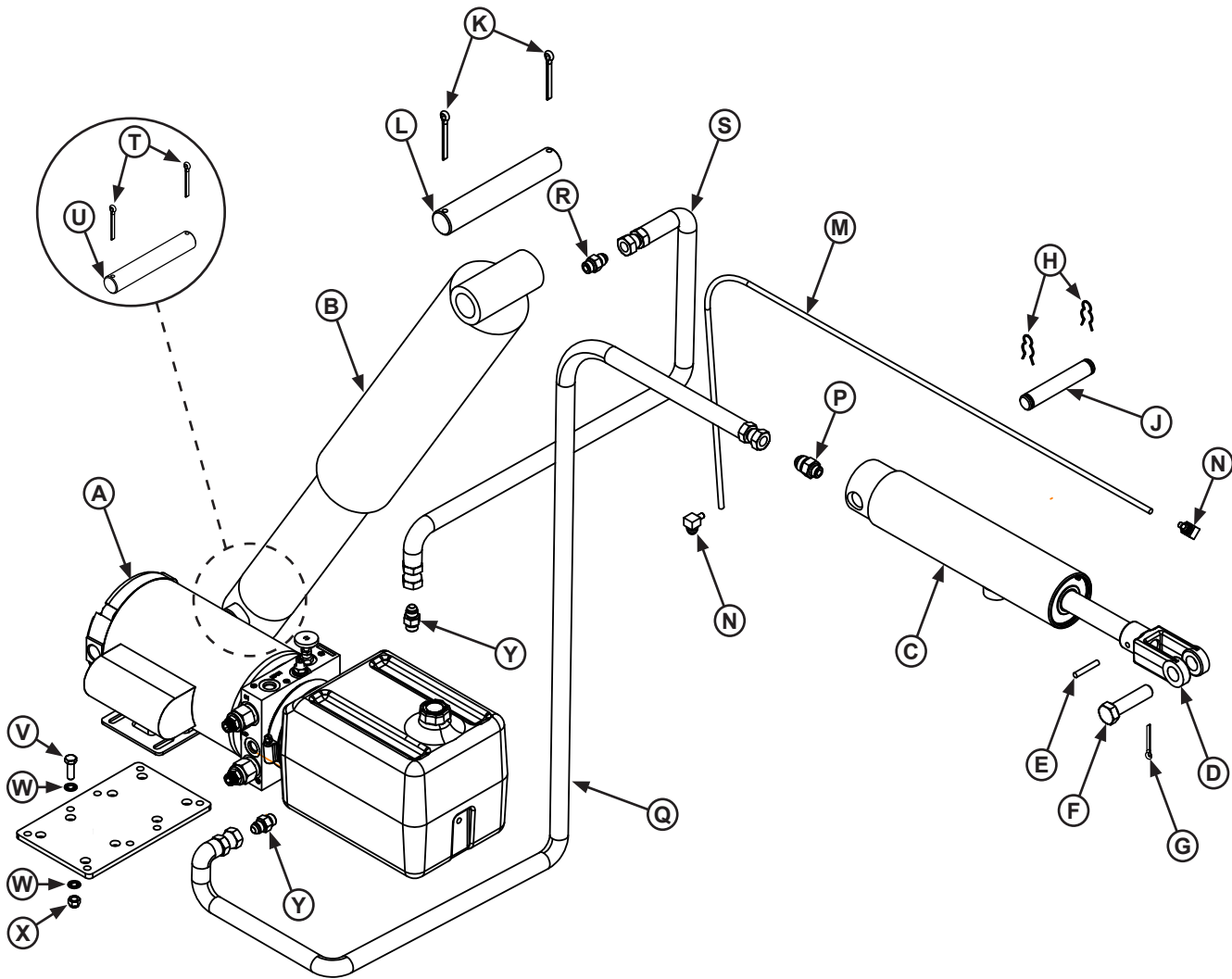

Hydraulic Components

Item	Quantity	Part Number	Description
A	1	9391-0045	Powerpack, 1-Phase, 115/230V
		9391-0046	Powerpack, 3-Phase, 208/230/460/575V
B	1	0521-0159	Cylinder, Platform, EH
C	1	0525-0085	Lip Cylinder, in. (mm) Barrel Length
D	1	0522-0189	Yoke
E	1	0521-0005	Roll Pin, 1/4" x 1.5" Long
F	1	0522-0005	Clevis Pin, 3/4" x 2", Plated
G	1	2101-0045	Cotter Pin, 1/8" Diameter x 1" Long
H	2	2101-0049	Clip, Hairpin, 5/8" Diameter
J	1	9202-0004	Pin, Lip Cylinder Mounting, 3/4" x 4.38" Long
K	2	2101-0047	Cotter Pin, 1/4" x 2" Long
L	1	9202-0058	Pin, Hoist Cylinder Mounting, 1.25" x 7.5" Long
M	1	R509-0060	Tube, Vent (3/8" OD x 1/16" Wall)
N	2	0521-0007	Elbow, 90° 1/4 NPT Male x 1/4 Tube
P	1	9301-0111	Fitting, #6-ORB Male x #8-JIC Male
Q	1	9904-0128	Hose, Lip Cylinder, 6' Leveler
		9904-0129	Hose, Lip Cylinder, 8' Leveler
		9904-0130	Hose, Lip Cylinder, 10' Leveler
R	1	8581-0127	Velocity Fuse, 4GPM, #8 Male Straight Thread ORB to #8-JIC Male
S	1	9904-0128	Hose, Platform Cylinder
T	2	2101-0047	Cotter Pin, 1/4" x 2" Long
U	1	9202-0059	Pin, Hoist Cylinder Mounting, 1.25" x 5.5" Long
V	4	2101-0011	Cap Screw, 5/16-18 UNC x 1 in.
W	8	2101-0058	Washer, 5/16"
X	4	2101-0039	Nylon Lock Nut, 5/16-18 UNC in.
Y	2	9301-0109	Fitting, #6 SAE to #6 JIC

¹ Provide length and diameter of hose when e-mailing, calling or faxing orders.

² Provide length of lip cylinder when e-mailing, calling or faxing orders.

³ Provide dock leveler serial number, voltage, and phase when e-mailing, calling or faxing orders.

PARTS

Monarch/Bucher Powerpack Assembly (9/2010-present)

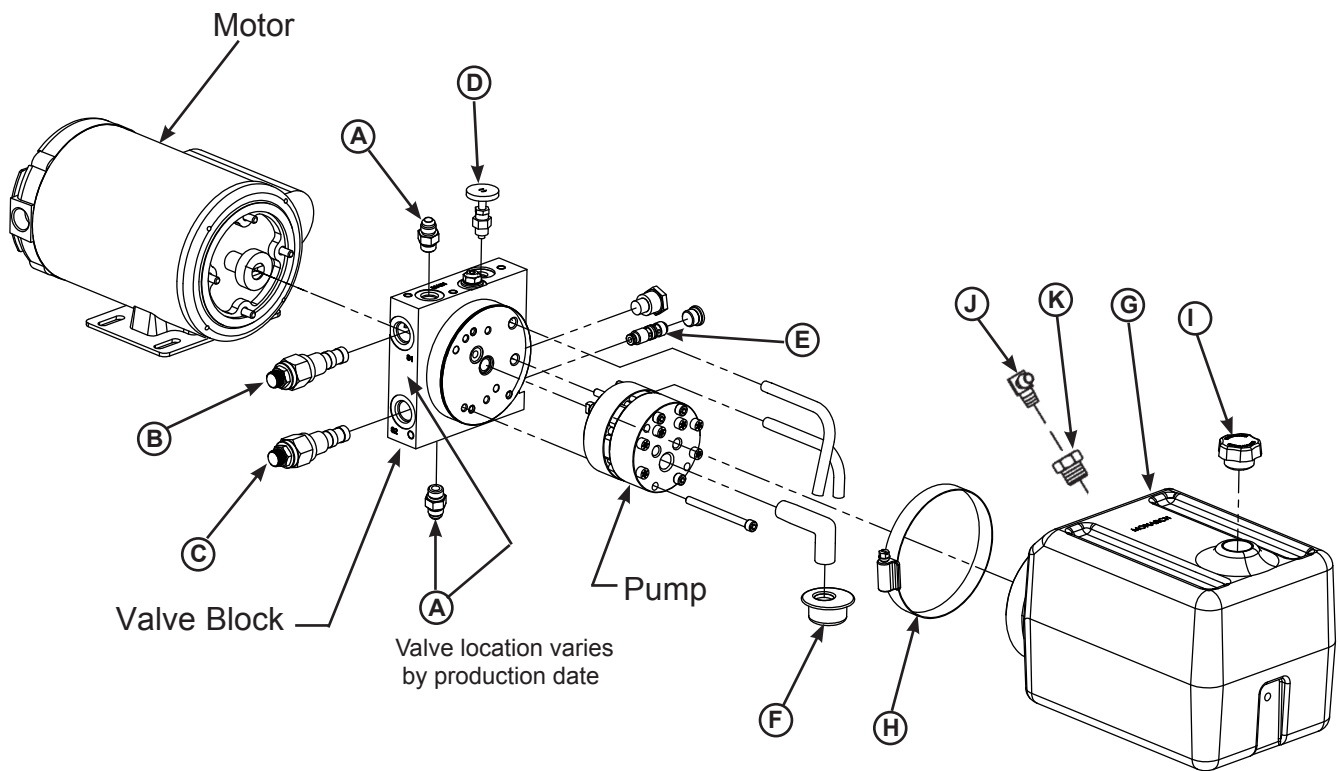

Monarch/Bucher Powerpack Components

Item	Quantity	Part Number	Description
A	2	9301-0109	Fitting, #6 SAE to #6 JIC
B	1	8581-0128	Valve, Sequence, S1 (Red Tip)
C	1	8581-0136	Valve, Sequence, S2 (Silver Tip)
D	1	8581-0151	Needle valve, Down Speed
E	1	8581-0150	Valve, Pilot Operated Check
F	1	9301-0232	Strainer, Suction
G	1	9301-0233	Reservoir, Plastic
H	1	9301-0234	Clamp, Reservoir
I	1	9301-0235	Breather
J	1	0521-0007	Elbow, 90° 1/4 NPT Male x 1/4 Tube
K	1	0521-0161	Fitting, Reducer, Pipe, 3/4" NPTM to 1/4" NPTF

Early Monarch Single Phase Wiring

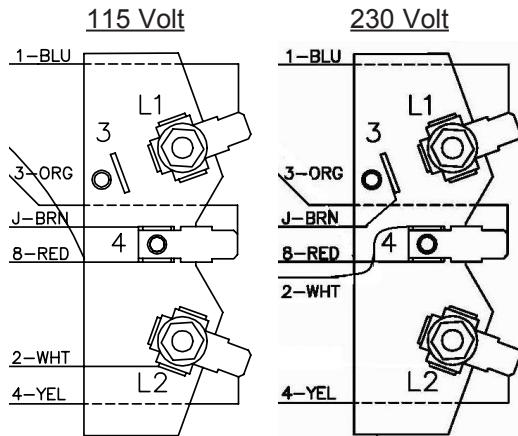

Notes:

Low Voltage: Move Lead J to Term. 4, Lead 2 to Term. L2
 High Voltage: Move Lead J to Term. 3, Lead 2 to Term. 4.

Current Monarch Single Phase Wiring

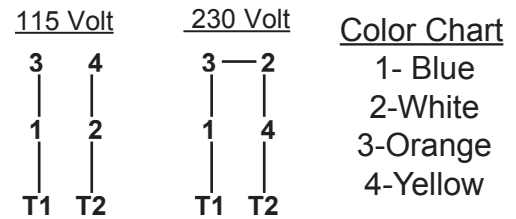

Monarch Three Phase Wiring

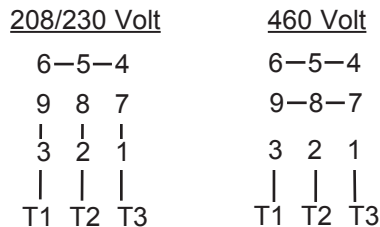

¹ Provide dock leveler serial number and type of installation when e-mailing, calling or faxing orders.

² Provide dock leveler serial number, voltage, and phase when e-mailing, calling or faxing orders.

PARTS

Hoke/KTI Powerpack Assembly (pre-9/2010)

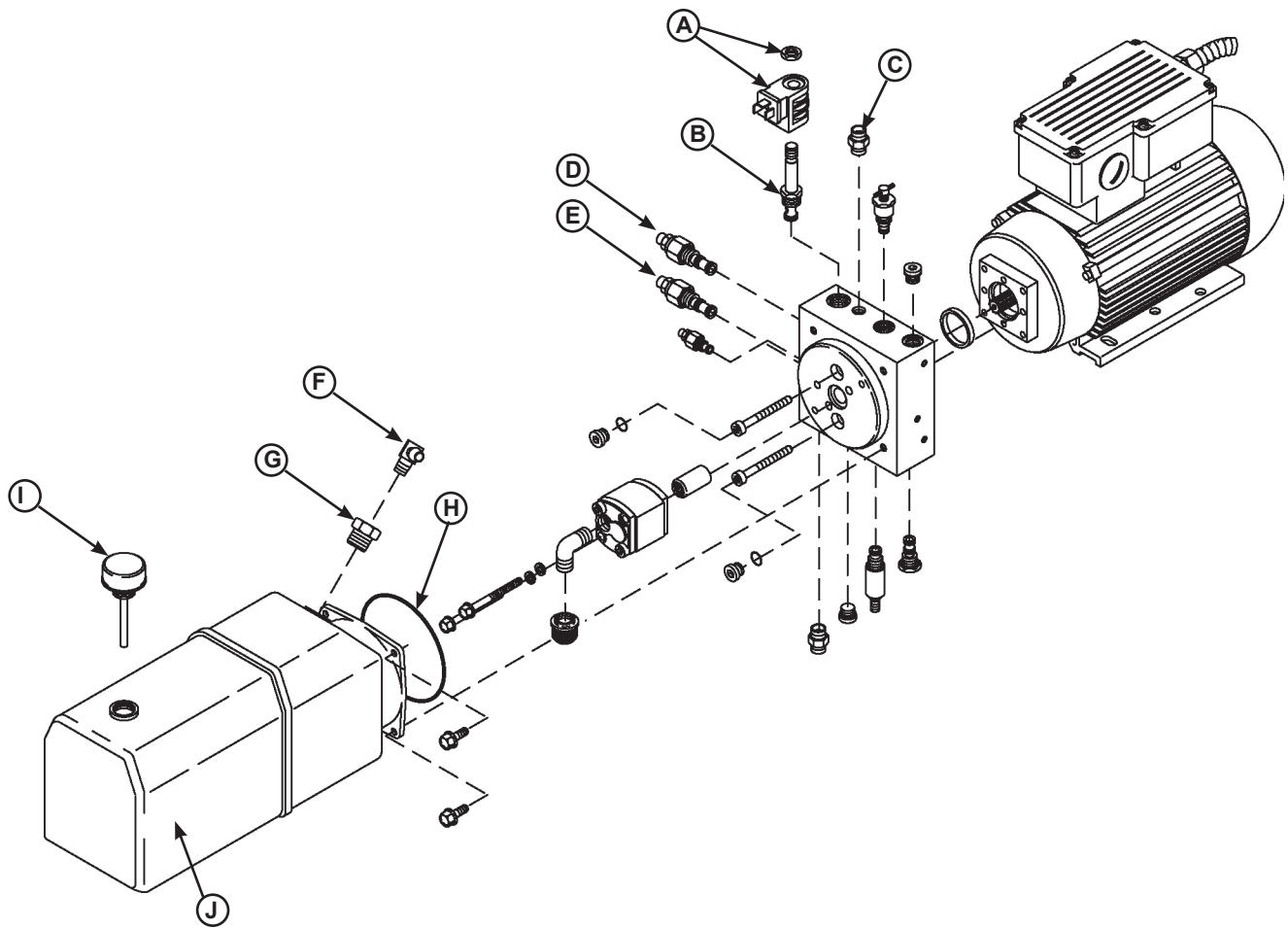

Hoke/KTI Powerpack Components

Item	Quantity	Part Number	Description
A	1	8581-0134	Coil & Nut for 8581-0133 Valve
B	1	8581-0133	Valve, 2 Way Normally Open
C	2	9301-0109	Fitting, #6 SAE to #6 JIC
D	1	8581-0128	Valve, Sequence, S1 (Silver Tip)
E	1	8581-0136	Valve, Sequence, S2 (Red Tip)
F	1	0521-0007	Elbow, 90° 1/4 NPT Male x 1/4 Tube
G	1	0521-0161	Fitting, Reducer, Pipe, 3/4" NPTM to 1/4" NPTF
H	1	9391-0032	O-Ring, Powerpack
I	1	9391-0031	Breather, Hoke Powerpack
J	1	9391-0030	Reservoir, 4 Quart, Hoke H8

Early Hoke Single Phase Wiring

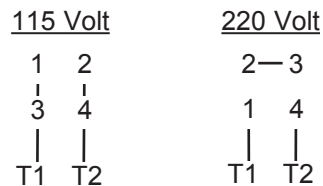

Late Hoke Single Phase Wiring

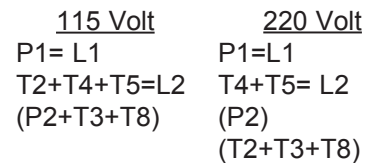

Hoke Three Phase Wiring

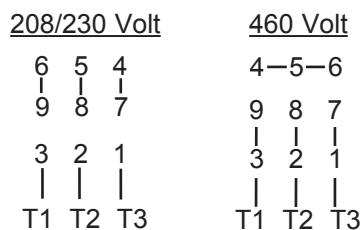

¹ Provide dock leveler serial number and type of installation when e-mailing, calling or faxing orders.

² Provide dock leveler serial number, voltage, and phase when e-mailing, calling or faxing orders.

PARTS

Valve Block - Emergency Stop/Lip Out

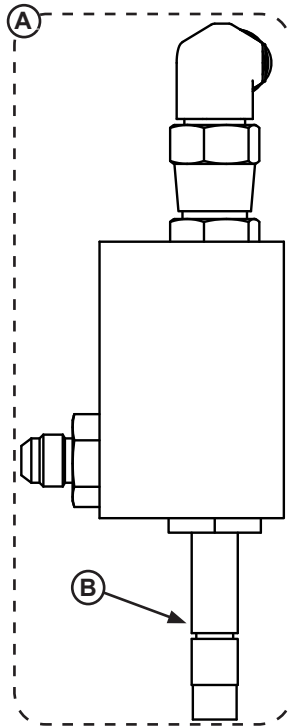

Item	Quantity	Part Number	Description
A	1*	8583-0072	Valve Assembly, Emergency Stop/Lip Out - Complete
B	2	8581-0116	Cartridge Valve, 2-Way N.O. Spool

*Provide dock leveler serial number when e-mailing, calling or faxing orders.

Weather Seals

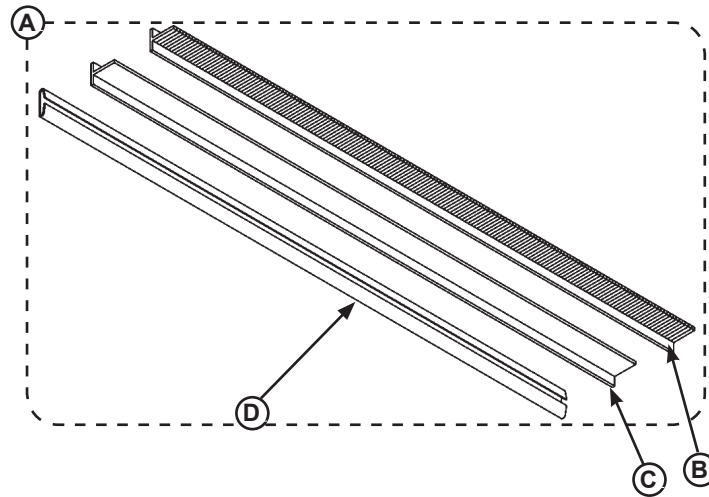

Weather Seal Kits

Item	Quantity	Part Number	Description
A	1	0195-0021	Brush Kit (Includes Seal and Track), 1-1/2 in. 82" Lg. (Both Sides)
	1	0195-0033	Rubber Kit (Includes Seal and Track), 1-1/2 in. 82" Lg. (Both Sides)

Individual Replacement Seals

Item	Quantity	Part Number	Description
B	1	0192-0098	Brush Refill, 1-1/2 in. 82" Lg.
C	1	0192-0085	Rubber Refill, 1-1/2 in. 82" Lg.
D	1	0192-0146	Replacement Channel

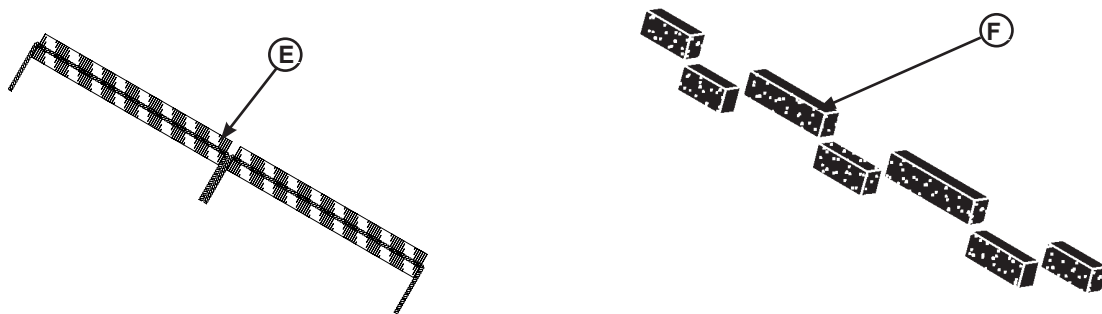

Rear Seals

Item	Quantity	Part Number	Description
E	1	0195-0044	Rear Brush Weather Seal, Universal
F	1	0195-0046	Rear Foam Seal, Self-Adhesive, Pre-Cut, 6' Wide Levelers
		0195-0047	Rear Foam Seal, Self-Adhesive, Pre-Cut, 6.5' Wide Levelers
		0195-0048	Rear Foam Seal, Self-Adhesive, Pre-Cut, 7' Wide Levelers

* Provide dock leveler serial number and size of platform when e-mailing, calling or faxing orders.

PARTS

Toe Guards

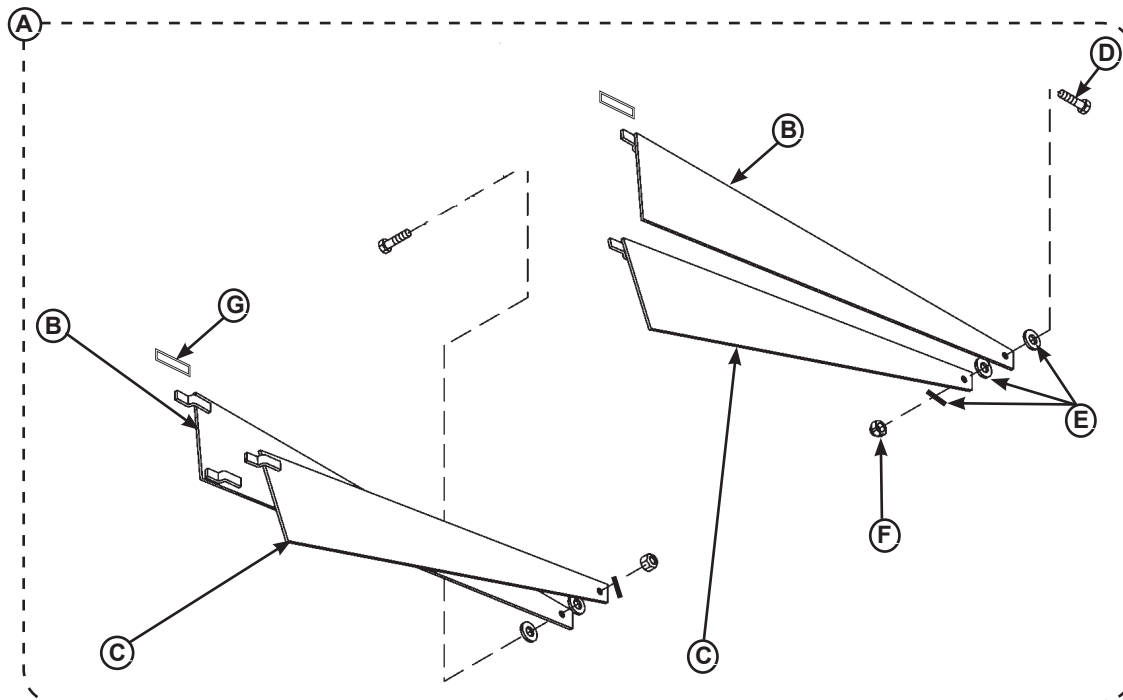

Item	Quantity	Part Number	Description
A	1	DKIT-9179	Toe Guard Kit, Sliding 6' (Includes Both Sides)
		DKIT-9180	Toe Guard Kit, Sliding 8' (Includes Both Sides)
		DKIT-9181	Toe Guard Kit, Sliding 10' (Includes Both Sides)
B	2	0011-0052	Toe Guard, Middle (6 Foot)
		0011-0054	Toe Guard, Middle (8 Foot)
		0011-0056	Toe Guard, Middle (10 Foot)
C	2	0011-0051	Toe Guard, Lower (6 Foot)
		0011-0053	Toe Guard, Lower (8 Foot)
		0011-0055	Toe Guard, Lower (10 Foot)
D	2	DOTH-2043	Cap Screw
E	6	DOTH-2207	Washer
F	2	DOTH-2131	Lock Nut
G	2	0011-0010	Platform Mounting Tab

* Provide dock leveler serial number and size of platform when e-mailing, calling or faxing orders.

Customer Information

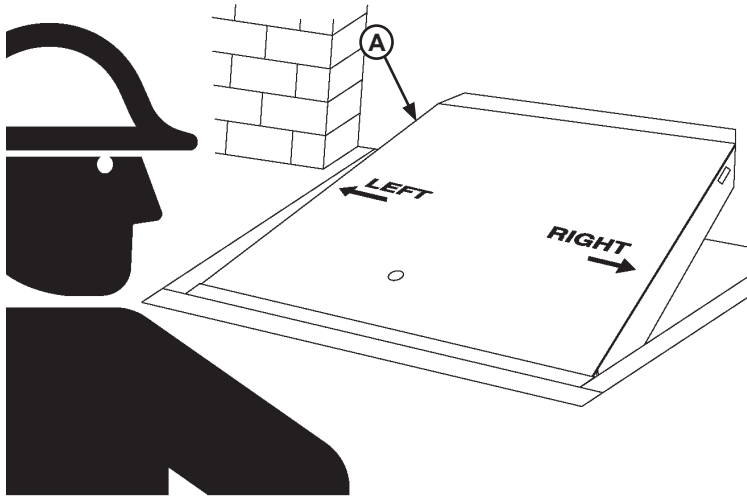

Figure 32

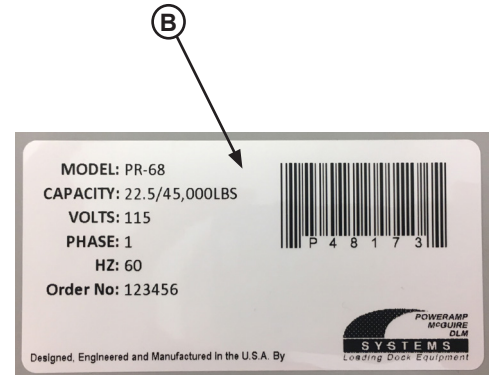

Figure 33

NOTE: Refer to Figure 32 for left/right orientation of dock leveler and Figure 33 for example of decal.

The LEVELER model/serial number decal is located on the left platform joist near the front (lip) of dock leveler (A).

When you receive your new equipment, write down the model and serial number in the form provided. This will help ensure safe keeping of the numbers in the event the model/serial number decal (A, B) becomes lost or damaged.

Also, write down Systems, LLC's order number, the company that installed the dock leveler, and the original owner's name. This will all help to identify the specific dock leveler if more information is required.

When ordering, use part numbers and description to help identify the item ordered. Do not use "item" numbers. These are only for locating the position of the parts. Always give dock leveler MODEL NUMBER and/or SERIAL NUMBER.

For service, call or contact:

Systems, LLC
P.O. Box 309
Germantown, WI 53022

Phone: (800) 643-5424
Fax: (262) 255-5917

www.loadingdocksystems.com

Dock Leveler Information

Model _____

Serial No. _____

Systems, LLC, Job No. _____

Vehicle Restraint Information

Model _____

Serial No. _____

Systems, LLC Order No. _____

Original Owner Information

Name _____

Address _____

Installer Information

Name _____

Address _____

Date of Installation _____

STANDARD PRODUCT WARRANTY

SYSTEMS, LLC warrants that its products will be free from defects in design, materials and workmanship for a period of one (1) year from the date of shipment. All claims for breach of this warranty must be made within 30 days after the defect is or can with reasonable care, be detected. In no event shall any claim be made more than 30 days after this warranty has expired. In order to be entitled to the benefits of this warranty, the product must have been properly installed, maintained and operated in accordance with all manufacturer's recommendations and/or specified design parameters and not otherwise have been subject to abuse, misuse, misapplication, acts of nature, overloading, unauthorized repair or modification, application in a corrosive environment or lack of maintenance. Periodic lubrication, adjustment and inspection in accordance with all manufacturers' recommendations are the sole responsibility of the Owner/User.

In the event of a defect, as determined by SYSTEMS LLC, covered by this warranty, SYSTEMS LLC shall remedy such defect by repairing or replacing any defective equipment or parts, bearing the cost for the parts, labor and transportation. This shall be exclusive remedy for all claims whether based on contract, negligence or strict liability.

WARRANTY LIMITATIONS

THE ABOVE WARRANTIES ARE IN LIEU OF ANY OTHER WARRANTIES, WHETHER EXPRESSED OR IMPLIED, INCLUDING BUT NOT LIMITED TO ANY IMPLIED WARRANTY OF MERCHANTABILITY OR FITNESS FOR A PARTICULAR PURPOSE. SYSTEMS LLC AND ITS SUBSIDIARIES SHALL NOT IN ANY EVENT BE LIABLE TO ANYONE, INCLUDING THIRD PARTIES, FOR INCIDENTAL, CONSEQUENTIAL OR SPECIAL DAMAGES OF ANY KIND INCLUDING BUT NOT LIMITED TO, BREACH OF WARRANTY, LOSS OF USE, LOSS OF PROFIT, INTERRUPTION OF BUSINESS OR LOSS OF GOODWILL.

PRODUCT SPECIFIC WARRANTY "DH" SERIES LEVELER

In addition to the "Standard Product Warranty" provided with all DLM® products, Systems LLC, guarantees materials, components and workmanship to be free of defects for the following extended periods:

- Structural Warranty – For an additional period of nine (9) years, product will carry a **prorated** structural warranty. This warranty specifically applies to; the deck section, lip section, frame, rear hinge assembly and front hinge assembly only. This warranty covers structural repairs to or replacement of dock leveler in Systems LLC sole discretion and expense including reasonable labor, materials, freight and travel. If Systems LLC determines replacement is necessary, it will provide the original purchaser with a credit toward the purchase of the new replacement Systems LLC product in the amount equal to the original purchase price of the warranted product F.O.B. point of manufacture, discounted on a ten year straight line basis by the number of years of use prior to replacement.
- Hydraulic Warranty – For an additional period of two (2) years, for parts, labor and freight, this warranty specifically applies to; the hydraulic pump and motor, all hydraulic cylinders, hydraulic pressure lines and fittings only.