

TPR UniLock® Vehicle Restraint Specification Sheet and Submittal

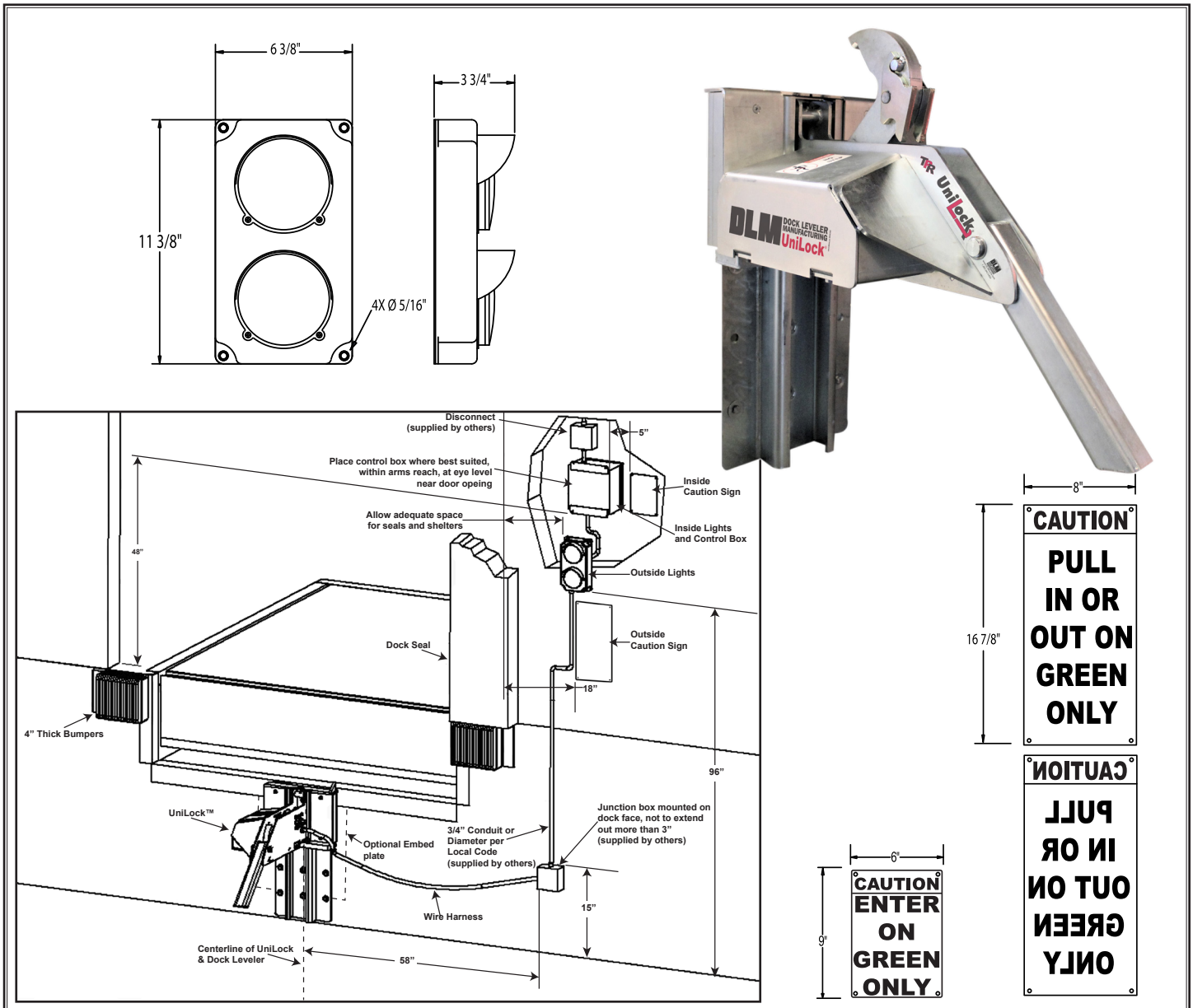

STANDARD FEATURES FOR THE UniLock® VEHICLE RESTRAINT

- iDock™ Controls with Interactive Message Display
- Restraining Force In Excess of 32,000 lbs.
- Industry Proven Truck Positioned Restraint Mechanism
- Locking Mechanism Maintains Engagement on the Trailer's Rear Impact Guard (RIG)
- Advanced Cam Design Rotates Hook Away from RIG to release "RIG Wedge" Pressure
- LED Internal and External Lights
- Universally Effective on Any Obstructed RIG, Including Intermodal Trailers with Cover Plates
- Low Profile 9" Carriage - Service Range 9"-30" Off Grade
- IP67 rated motor, submersion proof up to 1 meter
- Zerk Grease Fitting on Roller Shaft and Hook Assembly For Ease of Maintenance
- Exclusive Designed Gear Motor and Hook Latching Mechanism Keeps Hook Continuously Engaged



TPR UniLock[®] Vehicle Restraint Specification Sheet and Submittal

GENERAL DESCRIPTION: All DLM[®] TPR UniLock[®] truck positioned vehicle restraints are designed to secure a cargo trailer's Rear Impact Guard (RIG) to reduce the likelihood of premature trailer separation during the loading/unloading process. The UniLock vehicle restraint features an electric mechanical restraint mechanism, inside iDock[™] control panel, exterior communication lights and instructional signs.

CONSTRUCTION: The UniLock vehicle restraint system is a truck positioned restraint system designed to be permanently mounted to the loading dock foundation. Restraint back plate and housing shall be in a zinc finish for all weather protection. Once activated, the UniLock seeks the RIG and exerts positive pressure to reduce the possibility of premature trailer separation from the dock. The UniLock secures the trailer with over 32,000 lbs. of pull-out force. The motor is IP67 rated, making it submersion proof in up to 1 meter of water for 30 minutes.

OPERATION: As the truck backs into position, the RIG contacts the UniLock spring loaded structural steel housing which rides down its track, allowing the RIG to position itself on top of the housing. The exterior communication light is green and the interior light is red. Once trailer is positioned against the dock bumpers, the operator presses the ENGAGE button allowing the hook to secure the trailer to the loading dock. Once restrained, the interior light is green allowing the dock attendant to safely enter the trailer while the exterior light is red warning the driver not to pull away from the dock. The UniLock restraint maintains contact with the RIG and adjusts automatically with the trailer float motion to assure proper engagement at all times during the loading/unloading operation. After the loading is complete, the operator presses the RELEASE button. When the trailer is released and the restraint is safely stored the interior light changes to red while the exterior light changes to green.

If the UniLock is unable to secure the trailer's RIG, the restraint will communicate the fault condition on the message display and by flashing an amber "caution" light. If ByPass of the system is necessary, it is recommended that you secure the trailer by other means before proceeding with the loading/unloading process. In ByPass mode the exterior light is red the interior amber caution light accompanies the green light indicating to the dock attendant to proceed with caution.

HOOKING RANGE AND CAPACITY: The UniLock restraint system is designed to withstand a pulling force in excess of 32,000 lbs., giving an added margin of safety and protection. Maximum operational range is 4" to 10" horizontally from face of dock bumpers, and 9" to 30" vertically above drive approach.

EXTERIOR LIGHTS: Low profile, traffic style, red, and green LED lights are standard for communication to truck driver. A set of caution signs warns truck driver to "Back In or Pull Out On Green Light Only".

ELECTRICAL: The UniLock vehicle restraint is available as a stand alone unit or combined electronically in a single integrated control panel with your dock leveler selection. Electric motor is 1/10 HP TENV 115v single phase. Interior and exterior 12 volt LED lights are powered by an integral transformer located in the control panel. Electrical control panel is a NEMA 4X enclosure.

Please Note: Unless specifically noted on quotation, all electrical requirements, including mounting of control box, outside lights and signs, are the responsibility of others.

Integrated Control Panel Shown (Standard Size)



INSTALLATION: Requires mounting of locking unit, control panel, exterior lights and signs in strict accordance with DLM installation instructions. UniLock can be welded to an optional new construction embed plate or by installing 15 anchor bolts (included) plus 16" of weld to dock curb steel. Mechanical installation is recommended to be performed only by authorized DLM Representative.

WARRANTY: All UniLock vehicle restraints feature a full one (1) year base warranty on all structural, mechanical and electrical parts, including freight and labor charges in accordance with Systems, LLC's Standard Warranty Policy. Systems, LLC warrants all components to be free of defects in materials and workmanship, under normal use, during the warranty period. This base warranty period begins upon the completion of installation or the sixtieth (60th) day after shipment, whichever is earlier.

Optional Equipment for UniLock [®] Vehicle Restraint (Check options desired)	
<input type="checkbox"/> Integrated Control Panel	<input type="checkbox"/> Wall Mounting Embed Plate (recommended on new construction)
<input type="checkbox"/> Restraint Engaged Interlock with Leveler	<input type="checkbox"/> Approach Plate with Bracing (Brick and Block wall recommended)
<input type="checkbox"/> Leveler Stored Interlocking	<input type="checkbox"/> Pit Floor Mounting Plate
<input type="checkbox"/> Cantilever Bracket _____ Projection	<input type="checkbox"/> Special Nema ___ Enclosure <input type="checkbox"/> Other _____
*Options must also be selected on the iDock [™] Controls specification sheet	
<input type="checkbox"/> Other _____	<input type="checkbox"/> Other _____

Customer: _____	Certified For Construction: _____
Job: _____	By: _____
Location: _____	Date: _____
Number of Units: _____	Company: _____
Voltage/Phase: _____	City & State: _____
Represented By: _____	_____
SalesRep: _____	Drawing #: _____

SS UniLock 06/19

A continuing product improvement process is in effect at Systems, LLC. We reserve the right to make product changes without prior notice.